



CYPRES

Rigger's Guide for Installation

I	page		date of issue	update
N	23	Loop support discs	11/01/92	11/01/94
S	24	Sketch of loop attachment	11/01/92	
T	25	Installation of loops (2-pin container)	11/01/92	11/01/94
A	26	"	11/01/92	
L	27	Packing of 1-pin container	11/01/92	
L	28	Packing of 2-pin container	11/01/92	
A	29	Packing of 1-pin Pop Top	11/01/92	11/01/94
T	30	Packing of 2-pin Pop Top	11/01/92	11/01/94
I	31	"	11/01/92	
O	32	"	11/01/92	
N	33	"	11/01/92	
	34	"	11/01/92	
G	35	"	11/01/92	
E	36	"	11/01/92	
N	37	"	11/01/92	
E	38	Packing the reserve	11/01/92	
R	39	"	11/01/92	11/01/94
A	40	Cutter replacement	11/01/92	07/01/95
L	41	Battery replacement	11/01/92	07/01/95
I	42	Contents	11/01/92	
N	43	"	11/01/92	07/01/95
S	44	Installation in Vector I	11/01/92	
T	45	"	11/01/92	
A	46	"	11/01/92	
L	47	"	11/01/92	
L	48	Installation in Vector II	11/01/92	
S	49	Installation in Chaser	11/01/92	
P				
E				
C				
I				
A				
L				

	page		date of issue	update
I	50	"	11/01/92	
N	51	One Pin Tear Drop	11/01/92	
S	52	Installation in Javelin	11/01/92	
T	53	Installation in Talon	11/01/92	
A	54	Installation in Atom	11/01/92	02/15/95
L	55	Installation in Jaguar/Mini Jaguar	11/01/92	02/15/95
L	56	LOR II	11/01/92	
A	57	Installation in Ultra	11/01/92	
T	58	Installation in Invader	11/01/92	
I	59	Installation in Vulcan	11/01/92	
O	60	Installation in Mini Hawk	11/01/92	
N	61	Installation in Combination Tandem	11/01/92	
	62	Installation in Sweethog	11/01/92	
S	63	Installation in EOS	11/01/92	
P	64	"	11/01/92	
E	65	Installation in Top Flyer V	11/01/92	
C	66	Installation in Top Flyer VI	11/01/92	
I	67	Installation in Pitt III	11/01/92	
A	68	Installation in Warp III	11/01/92	
L	69	"	11/01/92	
	70	Installation in Centaurus	11/01/92	
	71	Installation in Wonderhog	11/01/92	
	72	"	11/01/92	
	73	Installation in ACE	11/01/92	
	74	Installation in NARO	11/01/92	
	75	Installation in Excaliber	11/01/92	
	76	Installation in Innovator II	11/01/92	
	77	Installation in Swift	11/01/92	
	78	Installation in Dual Hawk Tandem	11/01/92	

I N S T A L L A T I O N S P E C I A L	page		date of issue	update
	79	"	11/01/92	
	80	"	11/01/92	
	81	Installation in Vector Tandem	11/01/92	
	82	Installation in Galaxy Tandem	11/01/92	
	83	Installation in Zerox		11/01/94
	84	Installation in Swift II		11/01/94
	85	Installation in Eclipse		07/01/95
	86	Installation in Vector III		07/01/95
	87	Installation in Dolphin		07/01/95
	88	Installation in Prestige		07/01/95
	89	Installation in Sidewinder		07/01/95
	90	Installation in Orion		07/01/95
		Questionnaire		11/01/92
		Disclaimer		

This only applies to equipment used in the USA.

This manual contains information and instructions on installing Cypres in various harness container systems. Where the manufacturer of the harness container system has also issued written instructions for installation these must be followed.

As an alternative a US master rigger may seek his own approval following the procedure outlined in "A C 105 - 2 C".

Preface

The installation of Cypres requires considerable attention to detail. All riggers are therefore requested to study the manual carefully prior to commencing such installation.

Some of the descriptions are rather detailed, even when dealing with basic rigging activities. This is not meant to patronise, merely to ensure that no detail is overlooked.

Regular installation seminars for riggers are held by Airtec at our factory in Wünnenberg. We ask that all riggers installing Cypres who have not attended one of these seminars conform strictly to the information contained in this manual. Should you encounter difficulties with any aspect of installation do not hesitate to contact us. Please, do NOT experiment whilst trying to solve a problem. We shall answer all questions immediately and give advice and assistance wherever possible.

Notice to Riggers:

Because of safety reasons, the fact that the CYPRES setup configurations for each individual rig have been designed and tested by Airtec with the CYPRES, and because of liability concerns for you, the rigger, we must remind you that Airtec CYPRES set-ups (pouches, cutter elastics, etc.), and CYPRES loops and discs MUST be used with CYPRES AADs.

At the same time, as Airtec has performed testing on these setups and loop system ONLY with CYPRES, we must insist that CYPRES setups and loops NOT be used with any other AAD, because of the same safety and liability concerns.

We kindly ask you to check for these situations and correct any that you discover. Thank you for your understanding.

**Please: Never ever install Cypres by trial and error.
This could cause someone's death!**

Dieses Handbuch ist in deutsch erhältlich.

Ce manuel est disponible en français.

Cypres is a trade mark of Airtec GmbH (Ltd.)

US patents number 4858856 and 5024400, European patent number EP 0281 and German patent number P 37 07 294.3 have been granted for Cypres.

Airtec GmbH, November 1992

Rigger Kit

This manual is designed primarily for use by parachute riggers. It details the method of installing Cypres in most harness container systems (rigs).

Supplied with the manual is a special "rigger kit" containing parts and spares necessary for the task.

The kit consists of:

- (1) Rigger's Guide for Installation Manual
- (2) Rigger's Guide for Installation Video
- (3) two soft bodkins
- (4) three Cypres pull-ups
- (5) three support discs
- (6) three 0.7 m sections of adhesive cable housing
- (7) five elasticated release unit housings
- (8) 2 strips of velcro for fixture of control unit
- (9) 50 m of Cypres loop material
- (10) two fingertrapping needles
- (11) 1 container of silicone gel
- (12) 1 running loop housing
- (13) 1 screwdriver
- (14) 1 pilot chute strap (for 2-pin Pop Top systems)
- (15) 2 Cypres packing pins
- (16) 2 control unit pockets
- (17) Cypres installation checklist

We would welcome any constructive comments based on rigger's experience in installing Cypres.

Technical introduction

Cypres works by measuring air pressure and the rate of change of air pressure. Air pressure is of course the basis of altitude measurement. When Cypres is switched on it calibrates itself to the ambient air pressure and then memorises this as its zero or ground level. It re-measures the ambient air pressure once every 30 seconds thereafter, to check for any changes caused by weather and updates its memory accordingly. It thus always knows the latest actual air pressure and its memory is always set to the correct zero or ground level.

The microprocessor recognises the rapid pressure change when the aircraft takes off and at 100m above ground level (AGL) it changes to a fast calculation mode in which it obtains seven different release criteria once every 0.25 seconds. All of these criteria must be positive before the unit will fire. Once the unit passes 450m (1500ft) AGL in the climb it arms itself and becomes fully operational.

NOTE: Cypres will not work if the aircraft is exited before it reaches 450m (1500ft) AGL. Once the aircraft has climbed through 450m and Cypres has become fully operational, it will work for any exit height.

During a descent in the aircraft, in freefall or under canopy, Cypres will operate down to 40m (120ft) AGL, at which height it is of no further use and switches itself off.

Considerable efforts have been made to eliminate the influence of air vortices. Such vortices can cause erroneous altitude readings varying by more than 200 metres from the actual altitude.

You can observe these pressure differences when looking at your altimeter in freefall and turning from a belly down to a belly up position (or vice versa). The needle will shake and change to a higher (or a lower) altitude.

The diagram below shows the pressure changes in such situations:

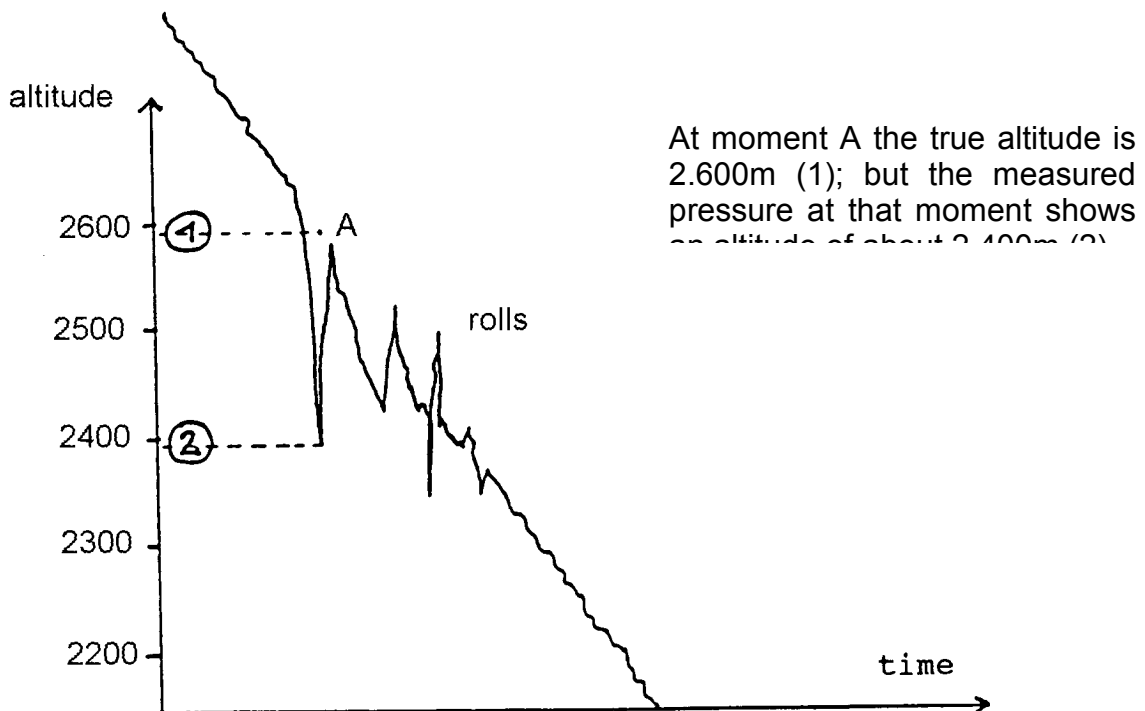

Previous AADs do not compensate for these erroneous fluctuations and are therefore inaccurate to a considerable degree. A precision AAD must be capable of instantly compensating for a wide range of fluctuations in dynamic pressure. Cypres is programmed to recognise the extremes of vertical velocity and acceleration to which every skydiver can be subjected and using this information, together with constantly updated pressure measurements, performs comprehensive mathematical routines which equate, in calculation power, to a normal personal computer. Even when Cypres is switched off it is not completely at rest, it is still checking to see whether or not the push button on the control unit has been pressed.

During the design stage much thought was given to making the release unit as safe and reliable as possible. This led to the development of the emergency opening system (EOS). The propellant charge in the EOS is only required to move the cutting blade a distance of 6mm and it does so with enough force to cut through a piece of steel wire 3mm thick. You would hardly expect such enormous power inside such a small device! The closing loop is cut instantly, resulting in an immediate reserve opening regardless of the condition of the pin(s). Apart from the push button on the control unit, the cutting blade is the only movable part of Cypres.

The Cypres release unit (EOS) is a dramatic improvement on all other systems currently available.

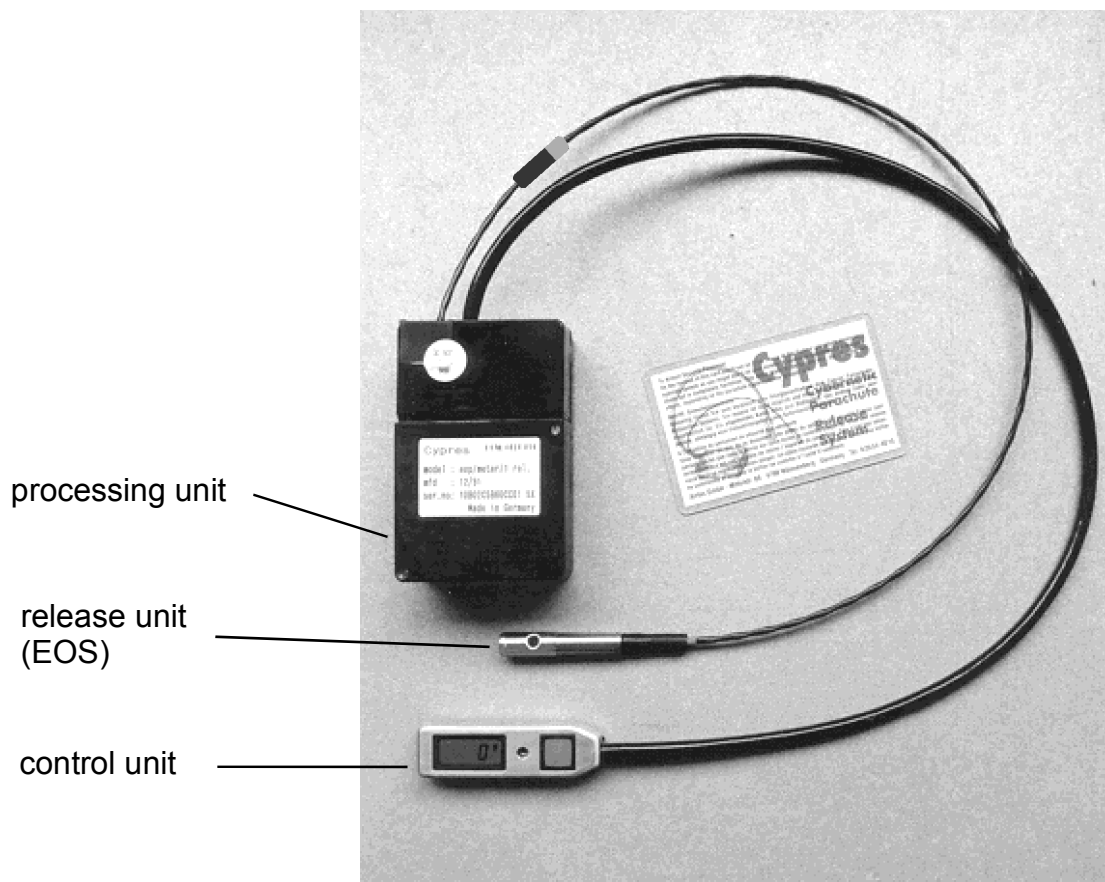

Installation General - Contents

General remarks	6,7,8
Installation of pocket for the processing unit - General	9
Installation of the release unit (EOS) - General	11
Installation of the control unit - General	
- Expert Cypres	15
- Tandem Cypres	15
- Student Cypres	18
Cypres reserve loops	20
Installation of loops in one-pin containers	22
Loop support discs	23,24
Installation of loops in two-pin containers	25
Packing of a	
- one-pin container with internally mounted pilot chute	27
- two-pin container with internally mounted pilot chute	28
- one-pin container with externally mounted pilot chute	29
- two-pin container with externally mounted pilot chute	30-37
Packing the reserve	38
Cable connections	40
Battery replacement	41

General remarks

If Cypres has not been incorporated in a harness container system (rig) by the manufacturer, it is normally fairly simple to retrofit. In some cases however, a great deal of skill is required.

All Cypres installations must be done by licensed riggers using this manual and any written instructions issued by the rig manufacturer.

Every Cypres is delivered with a comprehensive installation kit which comes in 2 bags.

The first bag is for use by the rigger, the second bag has to be handed over to the rig owner.

Contents of a 1-pin installation set :

1 pocket for processing unit
1 cable housing

1st bag :

1 elasticated release unit housing
1 control unit pocket
2 1-pin loops (in separate bag)
1 pull up
2 support discs
1 strip of velcro

2nd bag (for user/owner) :

1 1-pin loop
1 pull up
1 screwdriver (for battery replacement)

We request that you stow a ready made loop (of correct length, with loop properly tied to support disc) and a Cypres pull up in the surplus cable pocket whenever you install a 1-pin Cypres.

Contents of a 2-pin installation set :

1 pocket for processing unit
1 cable housing

1st bag :

2 elasticated release unit housings
1 control unit pocket
2 2-pin loops (in separate bag)
2 pull ups
2 support discs
1 strip of velcro
2 soft bodkins
1 running loop housing

2nd bag (for user/owner) :

1 2-pin loop
2 pull ups
2 soft bodkins
1 screwdriver (for battery replacement)

We request that you stow a ready made loop (of correct length), 2 Cypres pull ups and 2 soft bodkins in the surplus cable pocket whenever you install a 2-pin Cypres.

When Cypres is installed in a 2-pin reserve container with 2 separate loops (i.e.: no running loop), the loop supplied, which is spliced on both ends, has to be cut in two halves.

This applies to e.g. Mini Hawk, Dual Hawk Tandem and Requin systems.

When installing Cypres it is vital to ensure that:

- installation is carried out in accordance with the instructions in this manual and any written instructions issued by the rig manufacturer,
- the manual opening system for the reserve (i.e. pins, pack flaps etc.) is not obstructed in any way,
- the structural integrity of the harness is not affected (e.g. by inserting / removing stitching, etc.),
- the processing unit is positioned where it will be best protected from physical damage and extreme outside air temperatures. Information on correct positioning of the processing and control units is contained in the relevant sections of this manual,
- only original Airtec pockets and housings are used for the processing, release and control units,
- only original Cypres loops and pull ups are used when packing a reserve container with Cypres installed.
- When packing two-pin Pop Tops, the special Cypres pilot chute strap must also be used,
- the ambient temperature during installation is at least 10°C; otherwise, the cable will become too rigid.

A good reserve pilot chute is an important safety factor.

On systems with an internally-mounted pilot chute, we recommend that owners equip their rigs with one that has a hard top and a strong spring, such as the new Vector reserve pilot chute or similar. On two-pin Pop Tops, we recommend use of the Jump Shack pilot chute or similar.

Installation of the processing unit pocket - General

The pocket for the processing unit must be fixed inside the reserve container by sewing it to the partition wall.

Sew as close as possible to the outer of the two rows of stitches on the binding tape surrounding the pocket. Sew all the way round the pocket. If the pocket is only tacked on, or if the sewing is not at the outer edge of the binding tape surround there is a danger of the reserve suspension lines becoming trapped.

To provide maximum protection for the processing unit (against physical damage and extremes in outside air temperature), the pocket must be positioned so that the processing unit sits centrally on the reserve container partition wall.

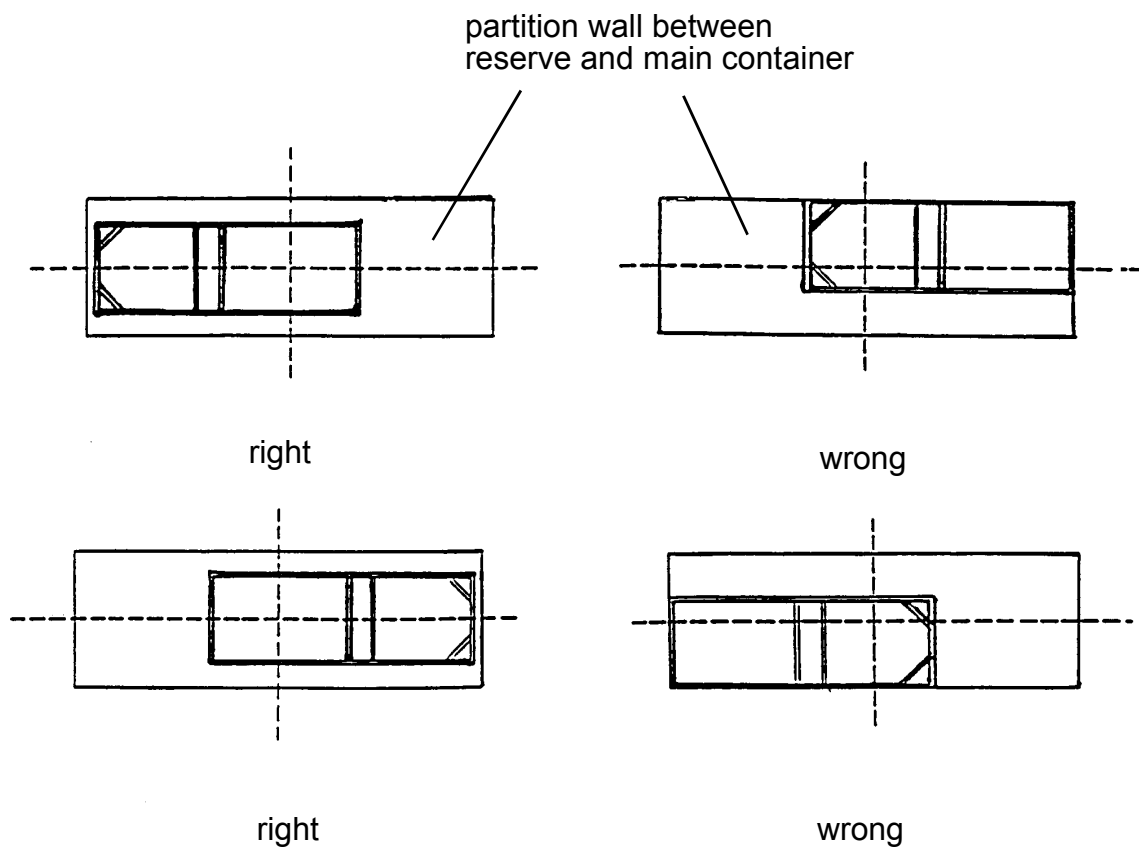

Position the processing unit so that the cables lie flat against the partition wall.

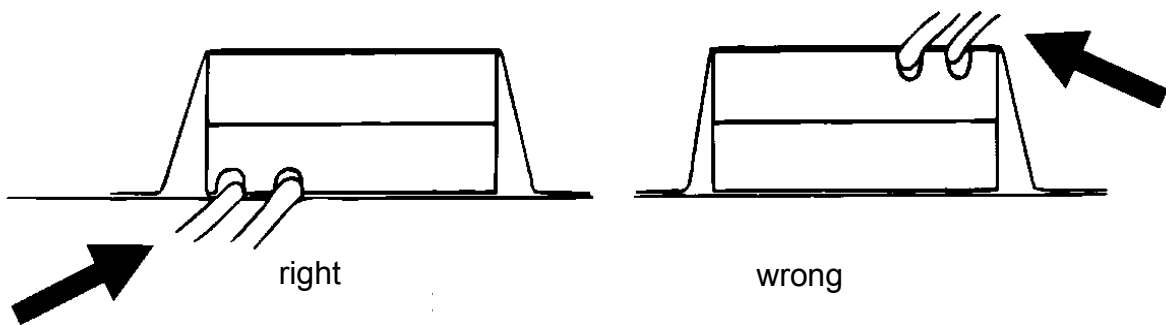

If the cables need to cross over each other anywhere inside the container, ensure that the thinner cable lies underneath the thicker one.

Coil any surplus cable into the small second pocket, the thicker cable uppermost. Ensure there are no kinks and coil as loosely as possible whilst still fitting in the pocket. Coils must not be smaller than the diameter of a 25 cent coin.

Then route the cables through the passage holes to the control and release units.

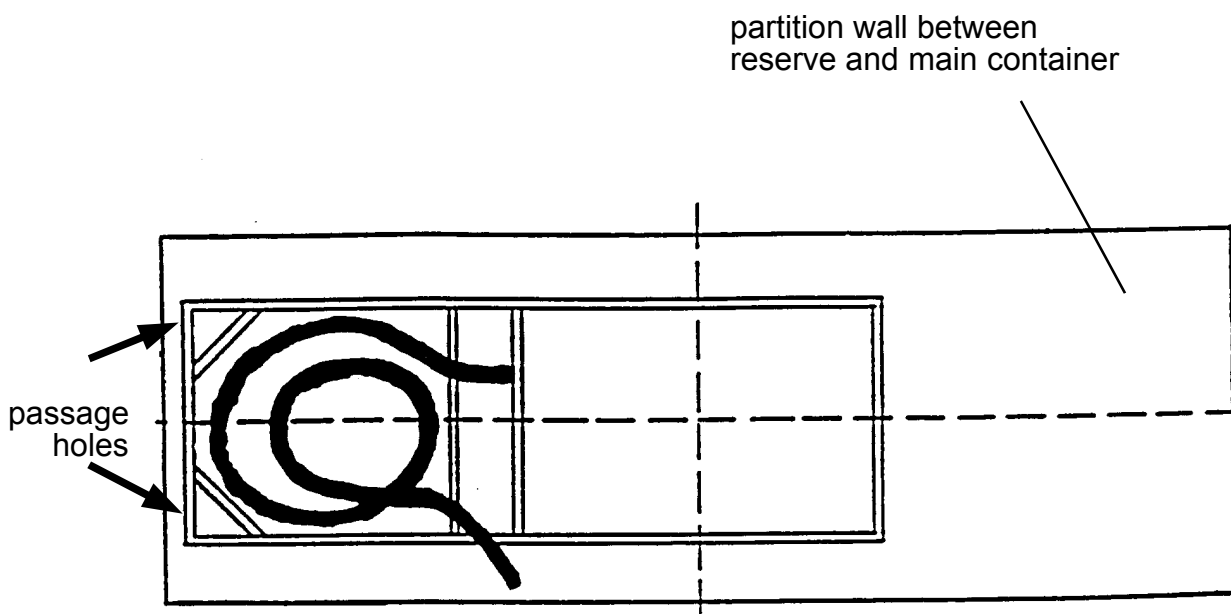

Installation of the release unit(s) (EOS) - General

Installation of the release unit(s) varies from system to system.

The release unit(s) can be mounted on the base of the reserve tray or on one of the reserve container closing flaps.

In a 2-pin Pop Top installation the control unit cable should be positioned hard against the edge of the stiffener plate so that it lies underneath the black plastic tapered end(s) of the release unit(s). This provides support for the unit(s), particularly if the stiffener plate is curved. If necessary secure the cable in the desired position with a couple of hand stitches (see diagram).

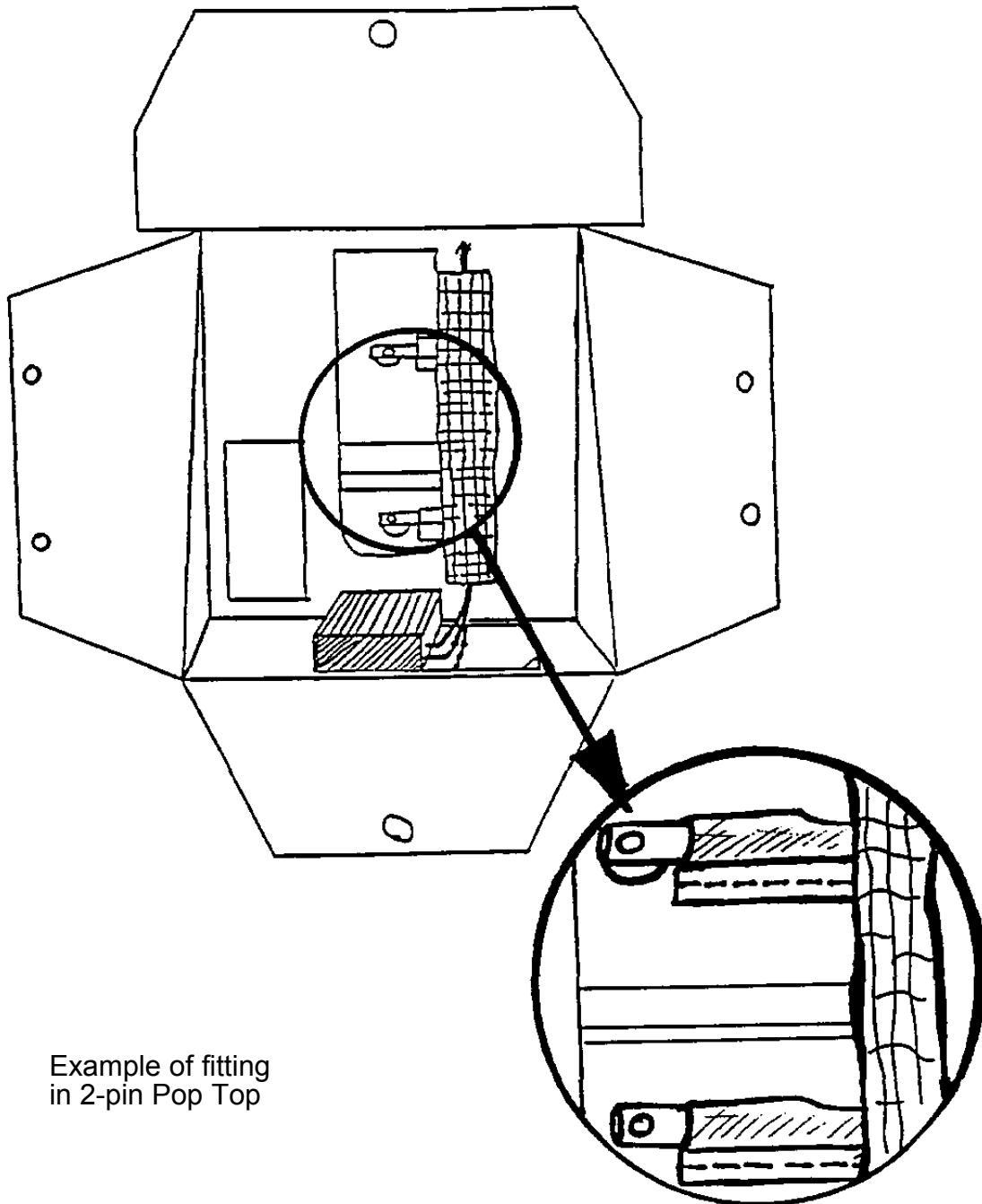

Example of fitting
in 2-pin Pop Top

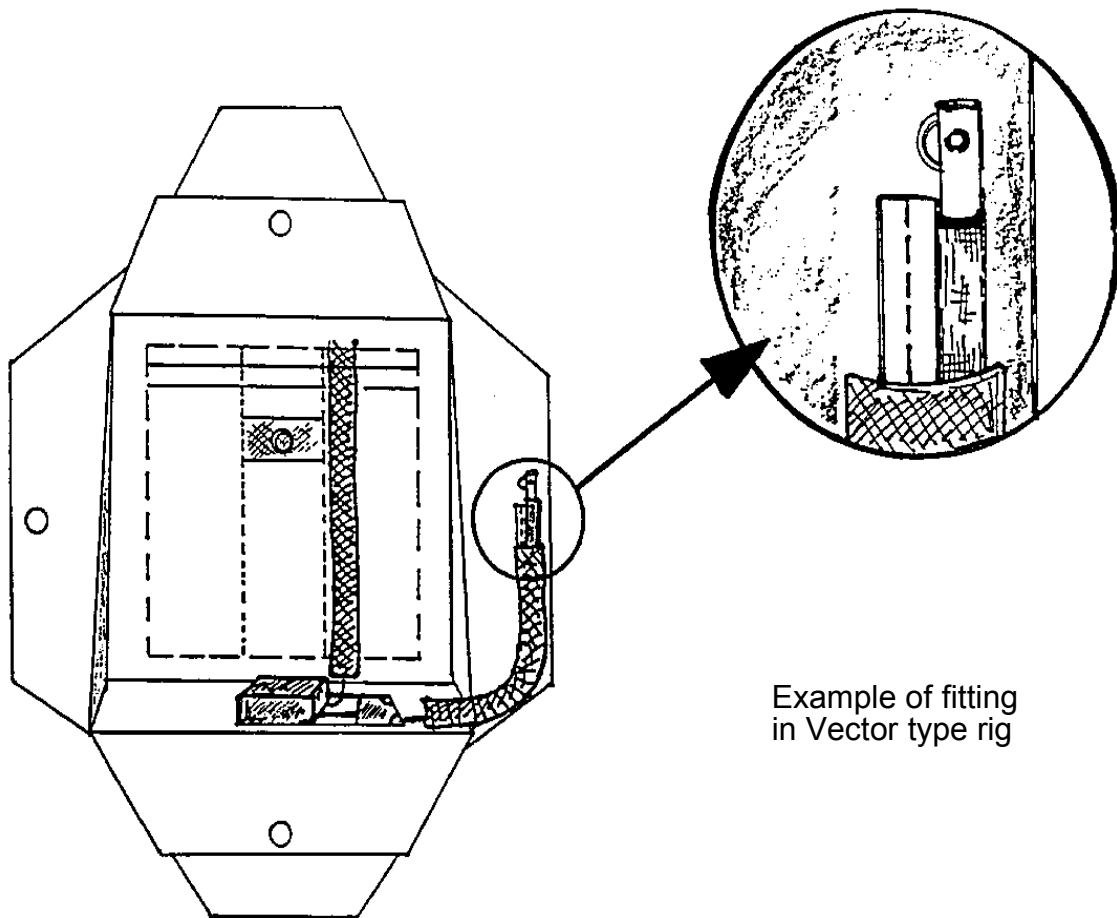

Example of fitting
in Vector type rig

Detailed instructions for installation in different rigs are contained in the "installation special" section. Should you wish to install Cypres in a rig for which no instructions are available you must contact Airtec for advice.

Never ever install Cypres by trial and error!

Position the release unit cable housing in the rig and fix in place using the adhesive coating. We strongly recommend that the housing is also sewn in place with a sewing machine or with thin wax thread.

The release unit must be pushed carefully through the cable housing and then through the elasticated housing until the loop hole is exposed.

If the release unit is to be mounted on the base of the reserve container, ensure that supplementary stitching of the housings is confined to the inner container wall only so that it is not visible from the outside.

We recommend the use of a "free arm" sewing machine. Alternatively, the housing can be neatly hand stitched.

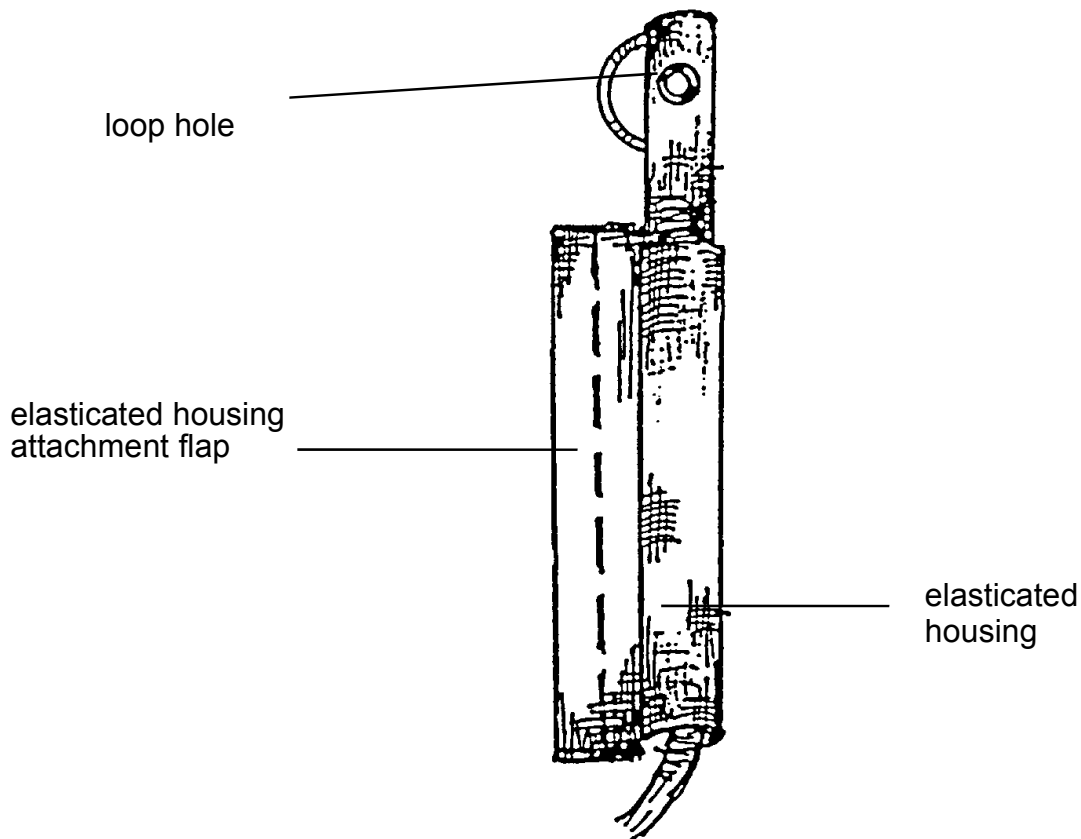

Note: The cable housing can be made of either ripstop nylon or a material similar to silk. If your housings are the silk type please ensure they are cut to size using a hot knife.

Please do not install the release element under flap 1, if there is a round reserve installed in the rig. Please install the release element in these cases under flap 3 (first flap above the pilot chute), this will prevent, that canopy material gets torn in the hole of the release element during packing. Release elements under flap 1 in rigs with round reserve should be located under flap 3 at time of next repack.

When a reserve is packed the closing flaps are always under tension and pull outwards against the closing loop. The closing loop will therefore always be hard up against an inside edge of each closing flap grommet, and this will always be the edge nearest to the free or tapered end of the closing flap.

When the release unit (EOS) is fitted to a reserve container closing flap (i.e. on Vector type containers with an internal pilot chute), it must be positioned so that the EOS loop hole is directly under the inside edge of the grommet against which the closing loop is being pulled (i.e. nearest the tapered or free end of the closing flap). The release unit must also be positioned so that the EOS loop hole is exactly perpendicular (i.e. at 90°) to the grommet.

When the release unit is fitted in the base of a container for a round reserve, cover the release unit(s) with a large piece of adhesive masking tape. Carefully cut a hole (or holes) for the reserve loop(s) to pass through. These holes must be no smaller than a one cent coin to prevent any possibility of masking tape being drawn into the EOS loop hole. The masking tape is used to ensure that there is no possibility of the reserve rigging lines becoming snagged on the release unit.

Installation of the control unit - General

Experience has shown that the control unit is best positioned under the pin protection flap on both Vector type and Pop Top rigs. Great care must be taken to ensure that the manual opening system for the reserve (i.e. pins, pack flaps etc.) is not obstructed in any way.

It is most important that there is no contact between the control unit and any metal component of the rig (i.e. grommets, pins etc.).

Study the specific installation instructions for the harness container system you are working on. Plan the general installation giving thought to the cable routing and whether or not you need to make passage holes in the container.

On Vector type rigs the control unit is normally fitted on the shoulder yoke next to the reserve ripcord housing. This housing is deeper than the control unit which is therefore protected and accessible at the same time.

The control unit can be attached to the cover flap in three ways:

1. Using the transparent pocket

Mount the pocket under the upper right section of the container's closing flap, roughly in the same position as shown on the drawing. Slide the control unit into position from the right side and close the velcro fastening. Do not cut off the nylon fixing ties, you may need them for subsequent fitting to a new rig.

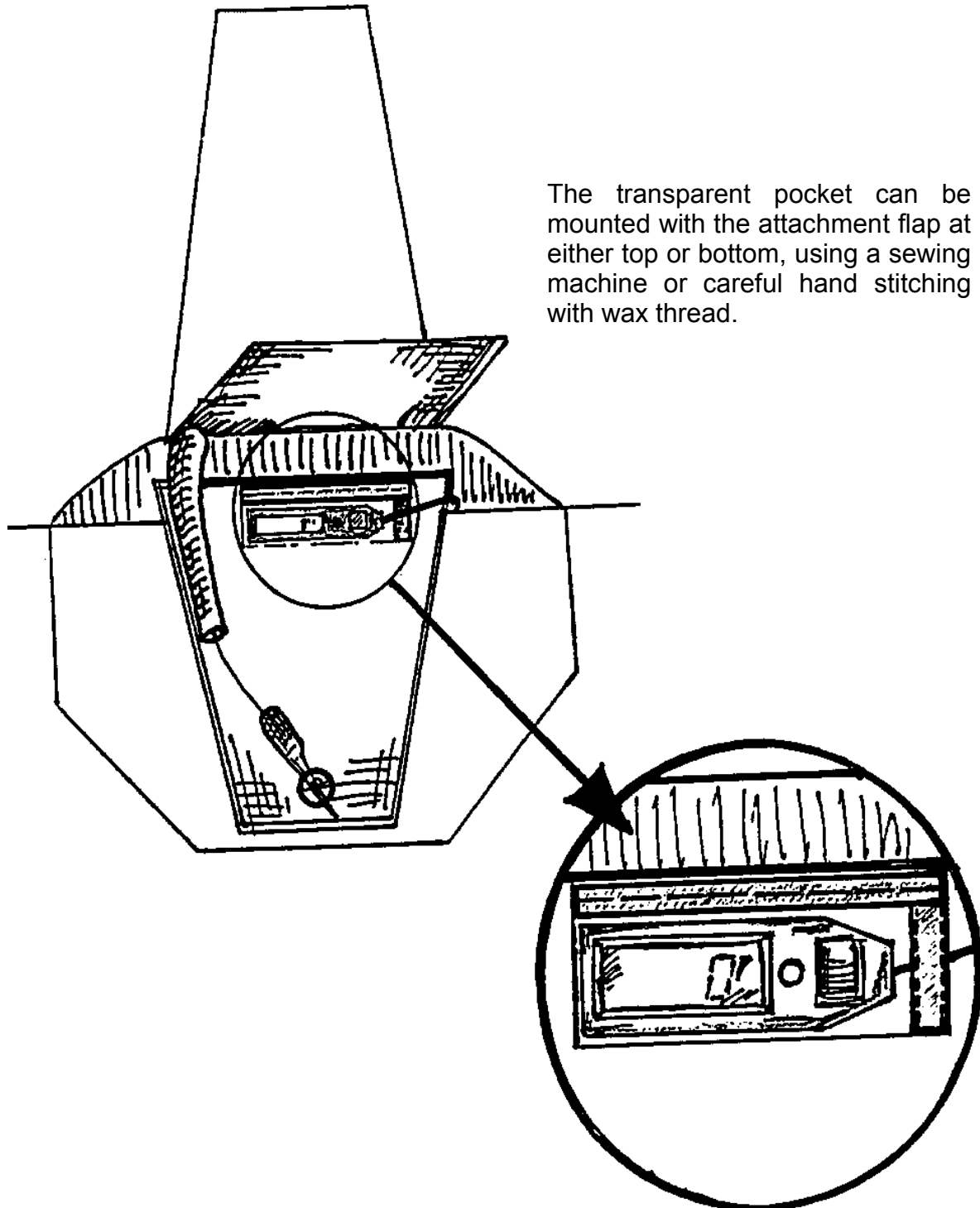

The transparent pocket can be mounted with the attachment flap at either top or bottom, using a sewing machine or careful hand stitching with wax thread.

2. Using the nylon fixing ties

Having determined the desired position for the control unit, pierce 4 holes with a needle for the fixing ties. If you need to drill through a reinforcement plate dress the holes with silicone. Thread the fixing ties through the material and tie firmly lengthwise (see diagram). Do not cut the fixing ties as they may be needed subsequently for fitting to a new rig.

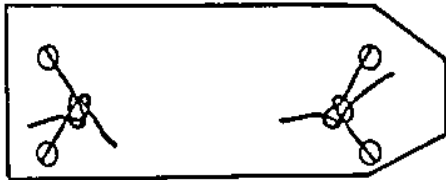

right

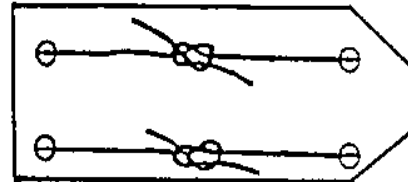

wrong



Using a hooked needle, thread any spare length of tie between the double fabric layer of the rig.

3. Using the velcro strip

Do not cut off the fixing ties, you may need them for subsequent fitting to a new rig. Coil them under the control unit and fix the self adhesive hooked velcro strip to the unit. Sew the pile velcro strip in the desired place on the reserve flap, stitching all the way round the edge. The use of velcro raises the control unit by 4mm.

We recommend using method 1 or 2. The glued velcro method should only be used:

- a) in Pop Top systems where it is impossible to drill or pierce through the reinforcement plate or
- b) in systems where the manufacturer has already incorporated the velcro in the appropriate position as part of a Cypres installation during manufacture.

page removed 11 / 2003

page removed 11 / 2003

Cypres reserve loops

Cypres loops are made from polyamide nylon cord and are specifically designed for use with the system. This is an innovative, very thin material with a diameter of 1.8mm and a breaking strain of approximately 180kp. The use of other materials could cause damage to the loop hole coating in the release unit and is NOT PERMITTED.

Cypres loops should never be shorter than those normally used on any particular harness container system (rig).

When the release unit (EOS) is mounted on the bottom of the reserve container the loop(s) should be of normal length for the rig in question. Do not shorten them unnecessarily as this causes extra tension and could lead to premature loop failure.

When the release unit is mounted on one of the reserve closing flaps the loop should be lengthened by up to 1cm in case of a one-pin container and up to 2cm in case of a 2-pin container to allow for the thickness of the release unit.

The entire reserve loop should be impregnated with silicone except for 1cm above the disc, after installing the loop to the disc. This increases flexibility and helps to ensure a fast reserve opening. It also ensures that during manual opening of the reserve the loop will slip through the loop hole of the release unit freely and it reduces the pulling force required.

When making your own loops, do not forget to treat them with silicone. This is simply done by rubbing the silicone into the loop material with finger and thumb (loop material and silicone are available from Airtec).

Before attaching the loop to the disc, stretch it by pulling on both ends at least twice. Pulling force is what matters, not the duration of the pull. A short but decisive pull will do. When the loop has been tied to the disc, repeat the procedure. A 2-pin loop should also be stretched before being put into the container. Once the required loop length has been established it should be annotated on the reserve packing card for future reference.

Each installation set is provided with 3 ready made reserve loops of sufficient length, 1-pin loops are impregnated with silicone on the first 4cm.

NOTE: As a general rule, the eye of any reserve loop should be as small as practicable to prevent the possibility of reserve canopy material becoming trapped. The diameter of a normal pencil or cigarette is ideal.

The potential weak spot in a reserve closing loop is where it is knotted through the washer. Excessive tension can lead to the cord breaking at the knot, or becoming so compressed that the knot slips through the hole in the washer.

To overcome this problem we have developed a support disc with 3 holes. The loop material is wound 2 times before being knotted.

The two windings absorb a great deal of strain resulting in very little decrease in the breaking strain at this critical point.

Loop installation in one-pin containers

When the release unit (EOS) is mounted on the bottom of the reserve container the loop(s) should be of normal length for the rig in question. Do not shorten them unnecessarily as this causes extra tension and could lead to premature failure.

When the release unit is mounted on one of the reserve closing flaps the loop should be lengthened by up to 1cm to allow for the thickness of the release unit.

The entire reserve loop should be impregnated with silicone except for 1cm above the disc after installation to the disc. This increases flexibility and helps to ensure a fast reserve opening. It also ensures that during manual opening of the reserve the loop will slip through the loop hole of the release unit freely and it reduces the pulling force required.

When making your own loops, do not forget to treat them with silicone. This is simply done by rubbing the silicone into the loop material with finger and thumb after installation to the disc (loop material and silicone are available from Airtec).

Before attaching the loop to the disc, stretch it by pulling on both ends at least twice. Pulling force is what matters, not the duration of the pull. A short but decisive pull will do. When the loop has been tied to the disc, repeat the procedure. Once the required loop length has been established it should be annotated on the reserve packing card for future reference.

Each installation set is provided with 3 ready made reserve loops of sufficient length. The 1-pin loops provided by Airtec are treated with silicone the first 4cm.

If the release unit (EOS) is mounted on the inside closing flap and is thus physically touching the pilot chute, the pilot chute must be of the stiff topped variety (new Vector type pilot chute or similar).

Loop Support disc

In order to avoid wear between loop, bottom disc and knot where the loop attaches to 1-pin containers and some 2-pin containers, we have developed a new technique for affixing the loop. This technique utilizes a metal disc with three holes together with a special knotting technique.

Installation using this technique will not take significantly longer than the procedure previously used but will have the added advantage that the entire loop system will have a higher tensile strength, about 180 kp.

Every Cypres intended for 1-pin containers is shipped with two of these special discs and three prepared loops. 2-pin Cypres come with two discs as well. The installation of the loop to the disc should be performed as follows (please find the sketch on page 26)

- a) pass the loop cord through the central hole and mark the desired length with a pen
- b) route the cord back through one of the outside holes
- c) and upwards again through the third hole
- d) hold to the disc between the index and the second finger and trap the spare cord with the thumb. Pass a pen through the loop and sharply pull the whole loop cord twice to prestretch the material.
Re-align the pen mark with the disc and knot the cord as shown in sketch e).
- e) make one further knot as shown in sketch f) to prevent slippage

Caution: Do not use other knots than suggested!

Sketch of loop attachment

Description of support disc knot:

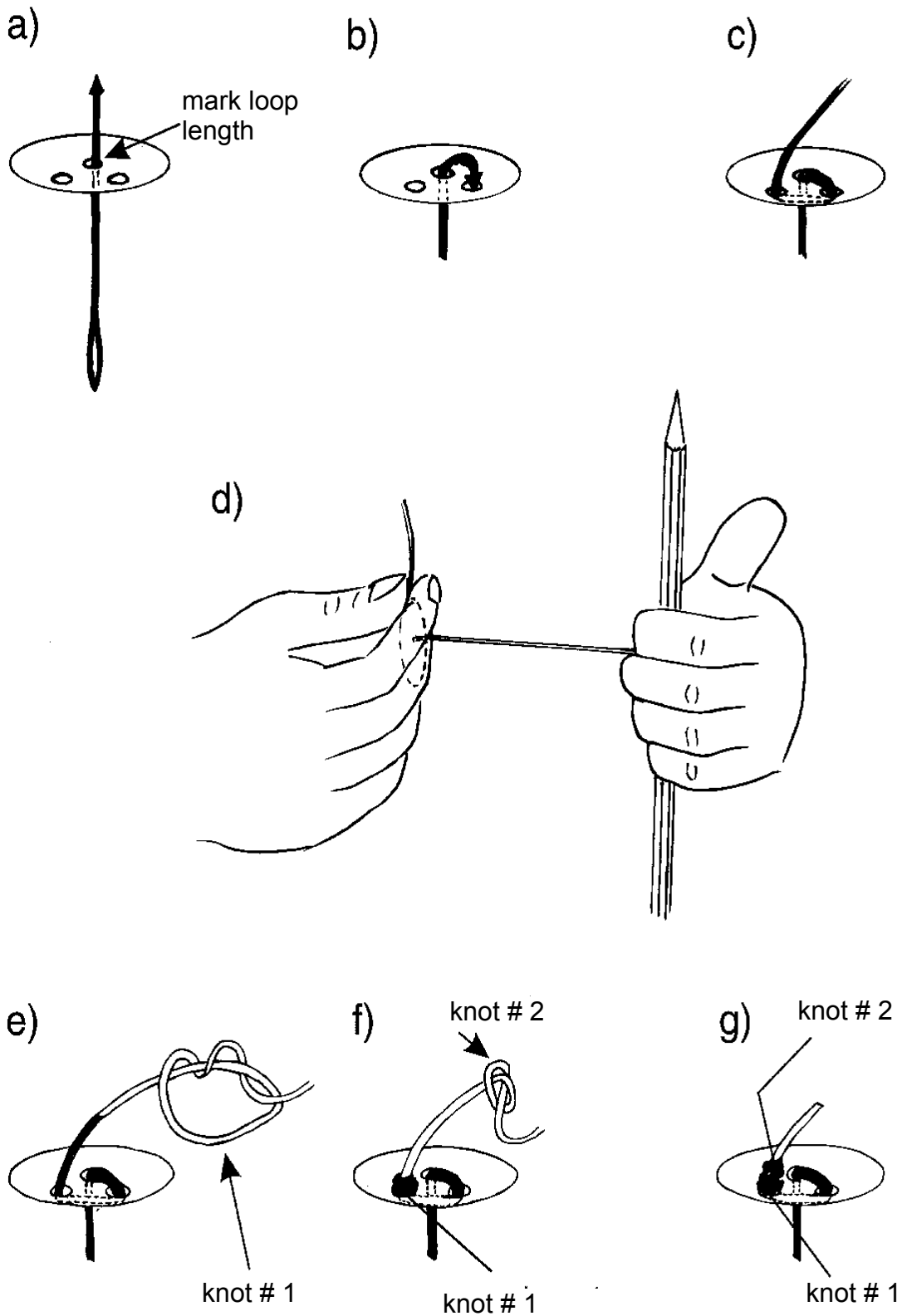

Loop installation in two-pin containers

Cypres loops should not be shorter as those normally used on any particular harness container system (rig).

When the release units are not mounted on the bottom of the container the loop should be lengthened by up to approx. 2 cm to allow for the thickness of the release units.

Assess the loop length required and adjust the loops accordingly.

Then, stretch the loop by pulling tight on both ends at least twice. The pulling force is what matters, not the duration of the pull. A short but decisive pull will do.

Adjust the loop by gently pulling the finger trapping until it is 1cm shorter than its desired length. Cut the protruding surplus ends with a scalpel or razor blade to a length of approximately 3mm. Then slowly pull the finger trapping until the surplus 3mm of material disappear inside the loop. The central 6cm of the loop should be sewn with nylon type E thread or similar material, by hand or machine. Machine sewing can be done with an ordinary home sewing machine or with a simple industrial machine, using a thin needle. If using an industrial machine, make sure it has a bottom transport mechanism and/or a needle transport. It is possible for the loop to become jammed in a multi-purpose transport. Both ends of the stitching should be locked. Care should be taken when sewing as the wrong thread tension could cause contraction of the loop. 2-pin loops provided by Airtec are not treated with silicone, please impregnate the complete running loop with silicone.

When making up your own loops, use only Airtec polyamide material. Make exact copies of original loops and do not forget to treat the complete running loop with silicone.

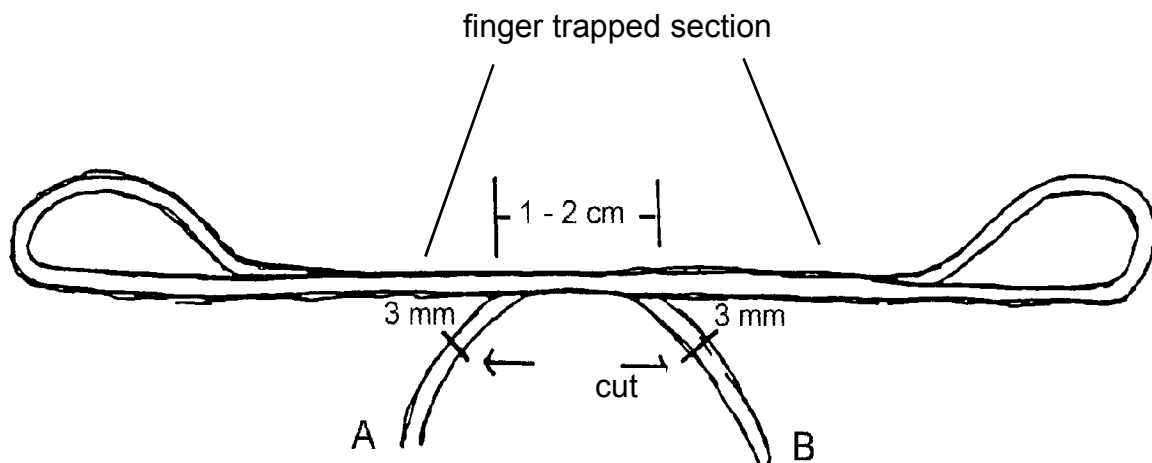

Important: The loose ends A and B should overlap in the centre of the made up loop by 1 to 2cm.

Finally, stretch the loop twice more.

This should result in a smooth, protrusion free loop of the required length.

Once the required loop length has been established it should be annotated on the reserve packing card for future reference.

The silicone gel supplied by Airtec does not affect Parapack, Cordura or Canopy material.

Packing

one-pin containers with internally mounted reserve pilot chute

Check the whole Cypres installation for condition and serviceability at each reserve repack. Make a special point of checking the plastic coating in the loop hole of the release unit (EOS). If this is damaged or displaced the unit must be returned to Airtec. Repair will be free of charge and the unit will be returned to the owner the day after receipt at our factory.

Check the loop for damage, especially at the release unit, the grommets and the ripcord pin. If the loop is damaged in any way it must be replaced.

When closing the reserve container the use of a straight pull on the pull up cord/closing loop is strongly recommended. The use of a twisting stick can impose unacceptable strain on the closing loop.

IMPORTANT NOTE 1:

Rapid and careless removal of the pull up cord can cause friction damage to the loop. To avoid damage remove the pull up cord by pulling it slowly against the underside of the ripcord pin.

IMPORTANT NOTE 2:

If, during packing, you need to pass the pull up cord through the loop hole in the release unit you must use the special Cypres polyamide pull up cord supplied. Use of any other material could cause damage to the plastic coating of the loop hole.

two-pin containers with internally mounted reserve pilot chute

Check the whole Cypres installation for condition and serviceability at each reserve repack. Make a special point of checking the plastic coating in the loop holes of the release units (EOS). If this is damaged or displaced the unit must be returned to Airtec. Repair will be free of charge and the unit will be returned to the owner the day after receipt at our factory.

Check the loops for damage, especially at the release unit, the grommets and the ripcord pin. If a loop is damaged in any way it must be replaced.

When closing the reserve container the use of a straight pull on the pull up cords/closing loops is strongly recommended. The use of a twisting stick can impose unacceptable strain on the closing loop.

IMPORTANT NOTE 1:

Rapid and careless removal of the pull up cord can cause friction damage to the loop. To avoid damage remove the pull up cord by pulling it slowly against the underside of the ripcord pin.

IMPORTANT NOTE 2:

If, during packing, you need to pass the pull up cord through the loop hole in the release unit you must use the special Cypres polyamide pull up cord supplied. Use of any other material could cause damage to the plastic coating of the loop hole.

one-pin containers with externally mounted reserve pilot chute

To protect the integrity of the fingertrapped or spliced section of the polyamide, loops for 1-pin Pop Top rigs should not be silicone impregnated.

Check the whole Cypres installation for condition and serviceability at each reserve repack. Make a special point of checking the plastic coating in the loop hole of the release unit (EOS). If this is damaged or displaced the unit must be returned to Airtec. Repair will be free of charge and the unit will be returned to the owner the day after receipt at our factory.

Check the loop for damage, especially at the release unit, the grommets and the ripcord pin. If a loop is damaged in any way it must be replaced.

When closing the reserve container the use of a straight pull on the pull up cord/closing loop is strongly recommended. The use of a twisting stick can impose unacceptable strain on the closing loop.

IMPORTANT NOTE 1:

Rapid and careless removal of the pull up cord can cause friction damage to the loop. To avoid damage remove the pull up cord by pulling it slowly against the underside of the ripcord pin.

IMPORTANT NOTE 2:

If, during packing, you need to pass the pull up cord through the loop hole in the release unit you must use the special Cypres polyamide pull up cord supplied. Use of any other material could cause damage to the plastic coating of the loop hole.

IMPORTANT NOTE 3:

When re-packing "Pop Top" reserve containers which are fitted with a Cypres part of the final inspection must be a visual check to ensure correct routing of the loop end through the cutter hole. This is to be done by looking through the grommet underneath the reserve pin in bright light conditions.

Whilst carrying out equipment checks at DZs or in Rigging lofts, extra attention must be paid to ensure that the loop is correctly routed.

two-pin containers with externally mounted reserve pilot chute

Check the whole Cypres installation for condition and serviceability at each reserve repack. Make a special point of checking the plastic coating in the loop hole of the release unit (EOS). If this is damaged or displaced the unit must be returned to Airtec. Repair will be free of charge and the unit will be returned to the owner the day after receipt at our factory.

Check the loops for damage, especially at the release unit, the grommets and the ripcord pin. If a loop is damaged in any way it must be replaced. Please tread the complete "running loop" with silicone before installation. When closing the reserve container the use of a straight pull on the pull up cords/closing loops is strongly recommended. The use of a twisting stick can impose unacceptable strain on the closing loop.

IMPORTANT NOTE 1:

Rapid and careless removal of the pull up cord can cause friction damage to the loop. To avoid damage remove the pull up cord by pulling it slowly against the underside of the ripcord pin.

IMPORTANT NOTE 2:

If, during packing, you need to pass the pull up cord through the loop hole in the release unit you must use the special Cypres polyamide pull up cord supplied. Use of any other material could cause damage to the plastic coating of the loop hole.

Two soft bodkins consisting of 1m of polyamide material with a loop at one end will be required. (Only use soft bodkins supplied by Airtec.)

We strongly recommend the use of a running loop system with Cypres in 2-pin Pop Tops.

IMPORTANT NOTE 3:

When re-packing "Pop Top" reserve containers which are fitted with a Cypres part of the final inspection must be a visual check to ensure correct routing of the loop end through the cutter hole. This is to be done by looking through the grommet underneath the reserve pin in bright light conditions.

Whilst carrying out equipment checks at DZs or in Rigging lofts, extra attention must be paid to ensure that the loop is correctly routed.

NOTE:

On Racer and Racer Elite systems in countries where US TSO standards apply, you must use the quick loop system in accordance with the manufacturer's instructions. Do not tread "quick loops" with silicone. For both running loops and quick loops however, you must use Cypres polyamide loop material.

Running loop installation

A 16cm running loop housing is supplied with every 2-pin Cypres. Should you require a housing of different length please contact Airtec for immediate delivery.

When making your own housings ensure that the ends are not cut with a hot knife. This leaves a sharp edge and can damage the running loop. The ends should be folded back and sewn in place in exactly the same way as on those supplied by Airtec. Handstitch the running loop housing to the top disc of the pilot chute with strong wax thread. Cross-stitch all four corners.

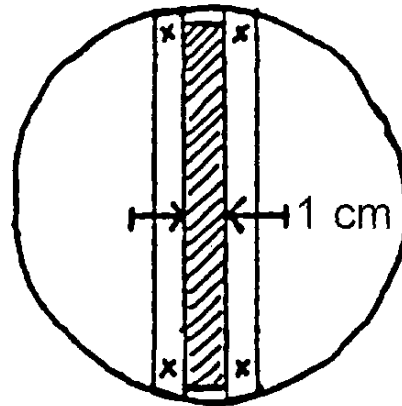

Using an original Cypres loop determine the length required for the rig and adjust the loop accordingly. It may need to be fractionally longer than normal due to the thickness of the release units (see page 25 for loop adjustment). Thread the loop through the housing on the pilot chute disc then pack the reserve.

The compressed pilot chute should be held closed using the strap provided. The pilot chute fabric must be stowed completely under the Pop Top cover and the use of the strap makes this whole operation much easier. When packing has been completed, remove the strap by very slowly and carefully pulling the velcro pile end underneath the pilot chute.

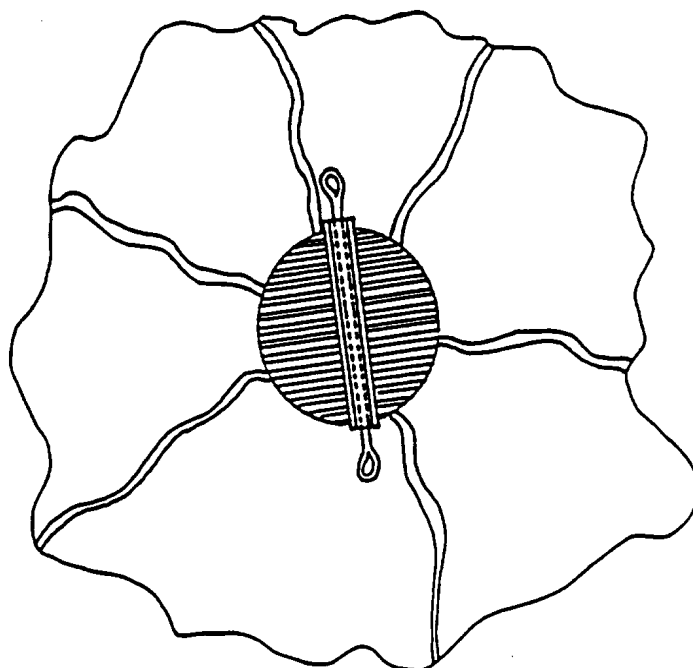

The control unit cable (\varnothing approx. 6 mm) should be positioned hard against the edge of the stiffener plate so that it lies underneath the black plastic tapered end(s) of the release unit(s). This provides support for the unit(s), particularly if the stiffener plate is curved. If necessary secure the cable in the desired position with a couple of hand stitches (see diagram).

In order to avoid that the plastic part of the cutter is bent, route the control unit cable under the plastic part and fix it with wax thread.

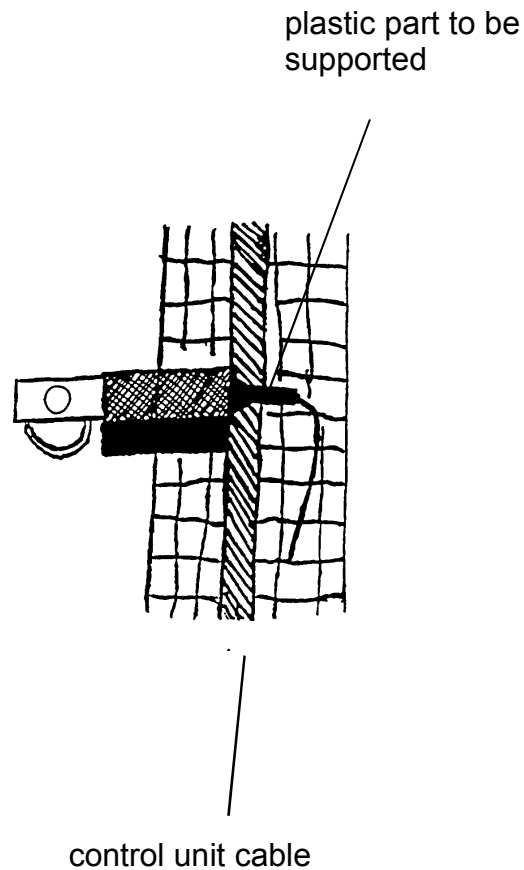

INTENTIONALLY BLANK

Pack the reserve using Airtec polyamide soft bodkins and pull ups. This is most important as both bodkins and pull ups made of other material could damage the loop holes in the release units. The technique is simple and is shown in the diagrams on the following pages:

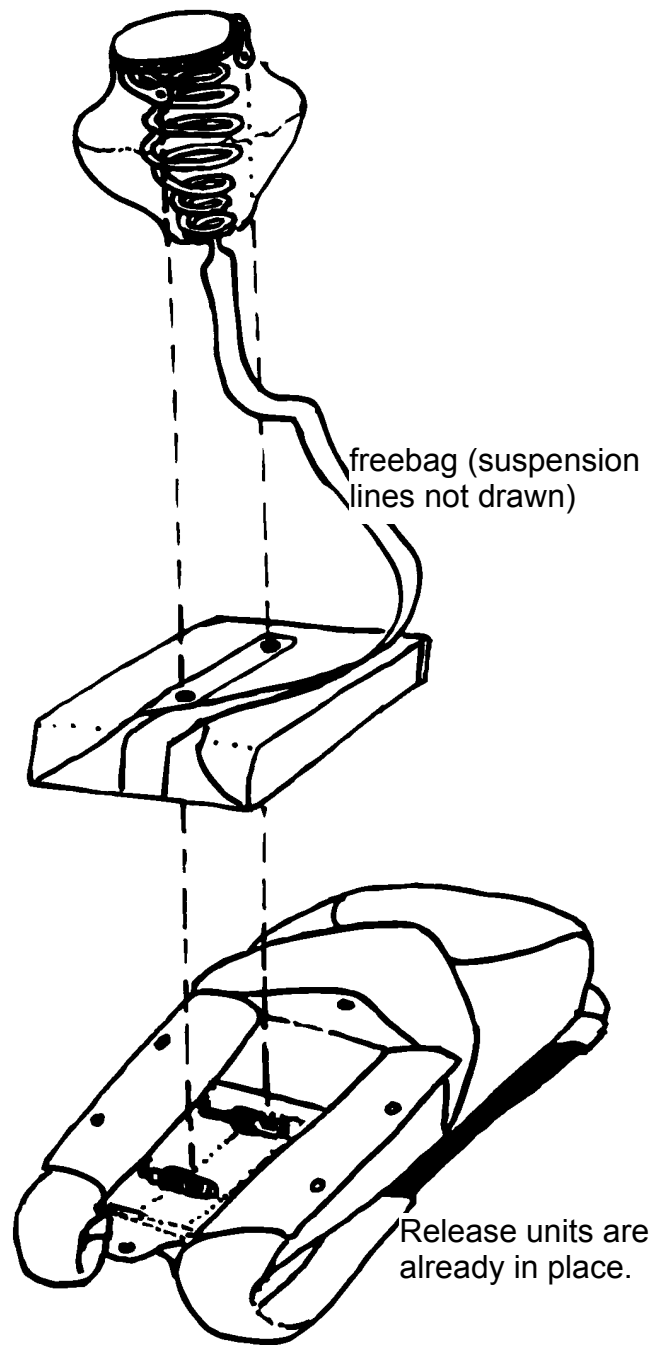

Using soft bodkins, pull the pull up cords through the freebag, the release units and the bottom of the container:

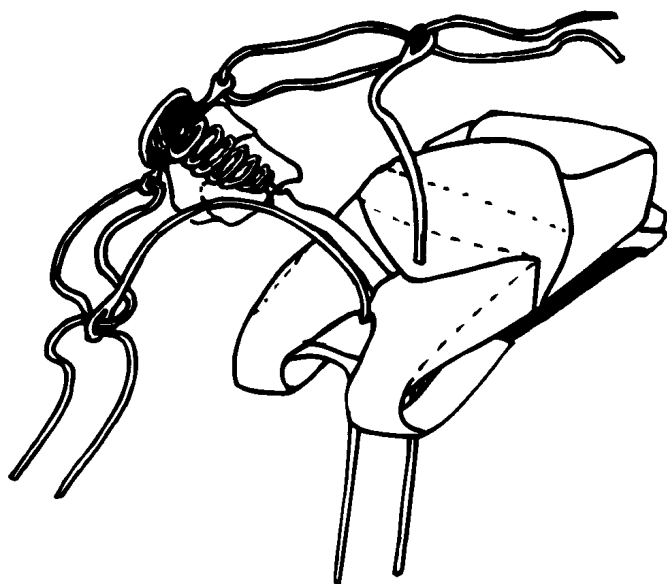
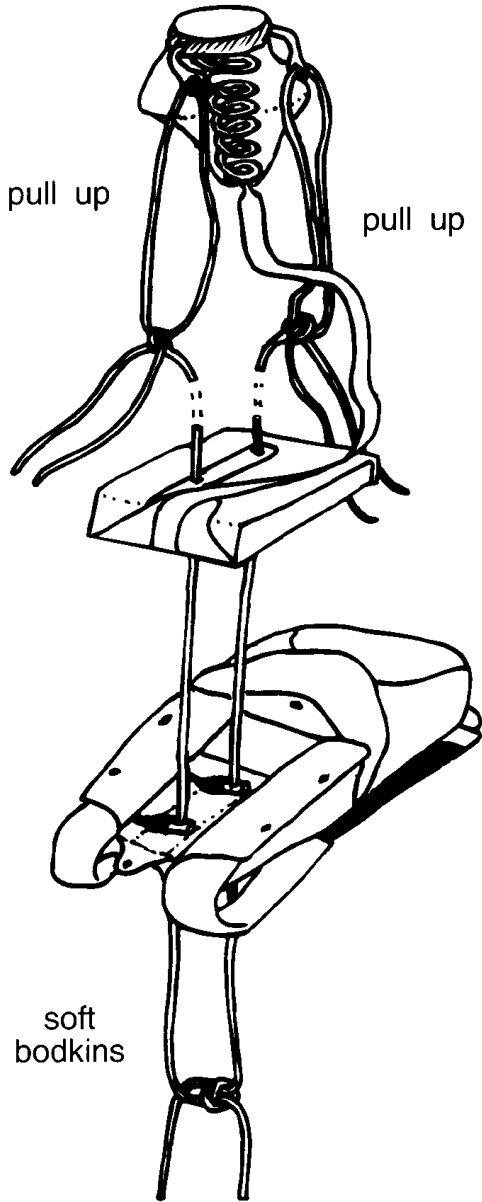

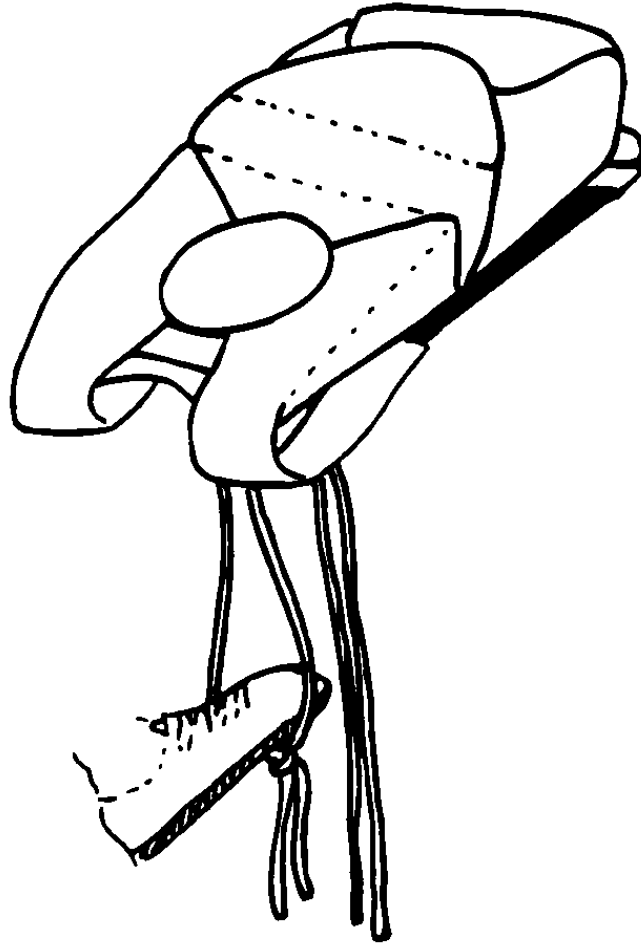

Once the pull up cords have been pulled through the closing loop grommets at the base of the container, the ends can be tied together. It is then possible to step into the resulting loop with one foot, creating enough force to close the container with little effort. (Place rig at the edge of the packing table).

To make insertion of the second ripcord pin easier, first insert the temporary pin supplied by Airtec. Carefully insert the ripcord pin underneath the temporary pin which can then be gently removed.

In order to facilitate the packing procedure described on the last three pages (p.34-36), we recommend that you push 2 conventional metal bodkins through the grommets at the bottom of the container to serve as a mechanical aid for the closing of the flaps.

The release units in their elasticated housings are mobile enough to allow temporary displacement while the bodkins are inserted, and they will move back to their original position once the bodkins have been removed. The bodkins can stay in place until all 4 flaps have been aligned properly.

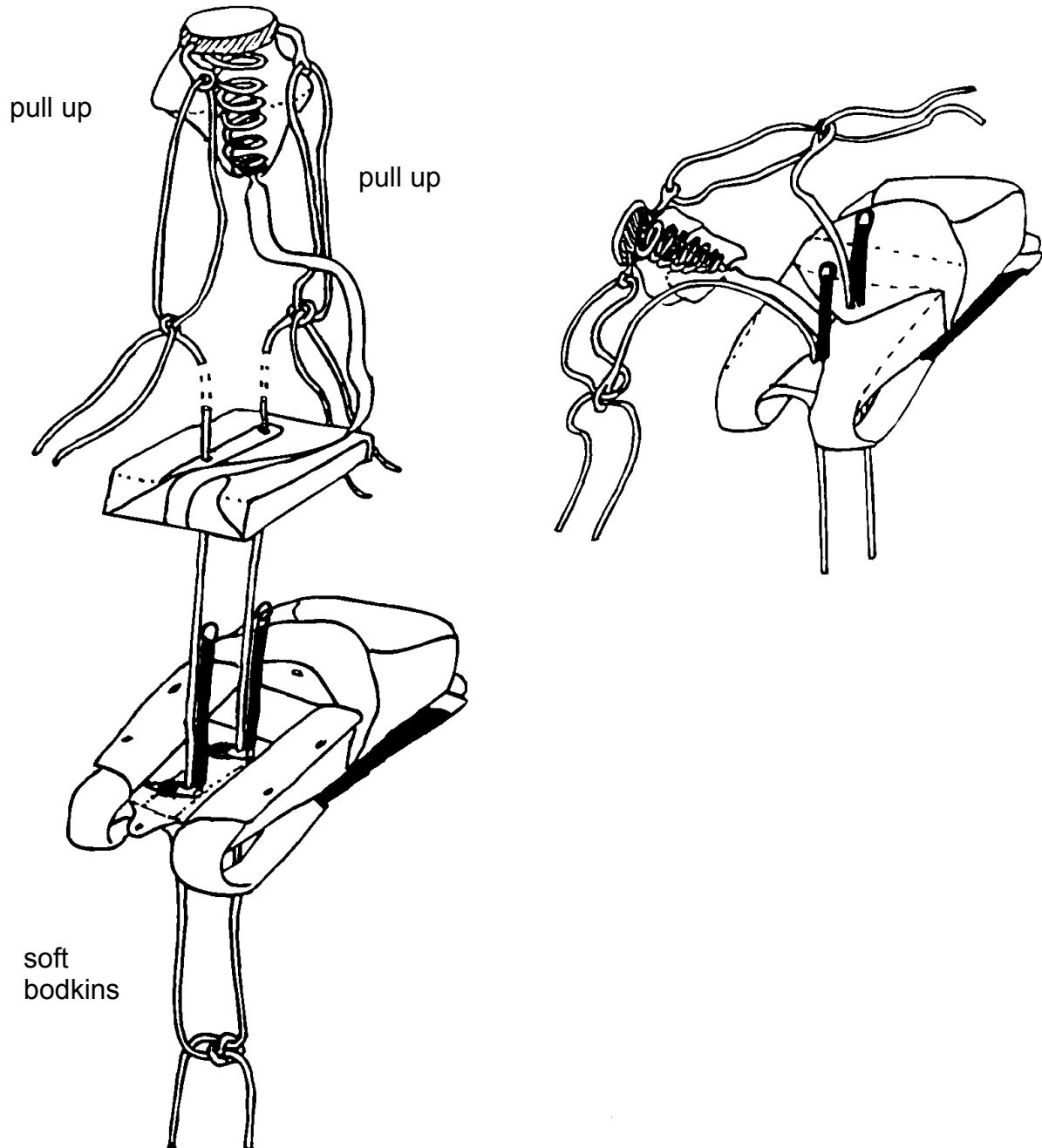

Packing the reserve

When placing the freebag in the container make sure that the connector links do not lie on top of any Cypres cables

As a general rule, the reserve canopy should be packed in a U-shape enveloping the Cypres processing unit as completely as possible and providing a smart exterior appearance.

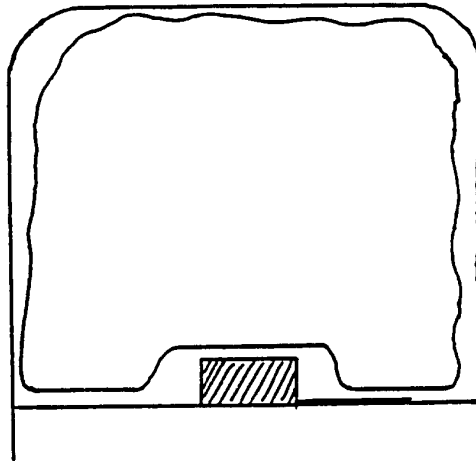

When installing round reserve canopies in two-pin containers, the loops must be routed through the open portions of the S-shaped canopy folds.

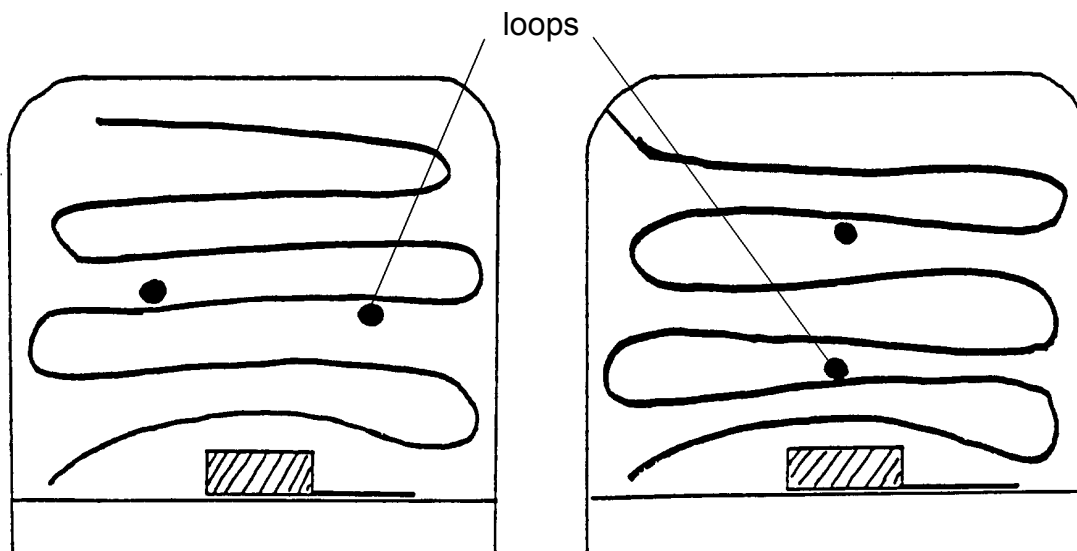

The same rule applies to suspension lines of round reserve canopies where the lines are stowed on the bottom of the container.

It is most important that riggers' lead seals are positioned well clear of the closing loop and grommet and thus cannot interfere with the reserve opening sequence in any way. (Neglect of this precaution caused a fatal accident in Spring 1992!)

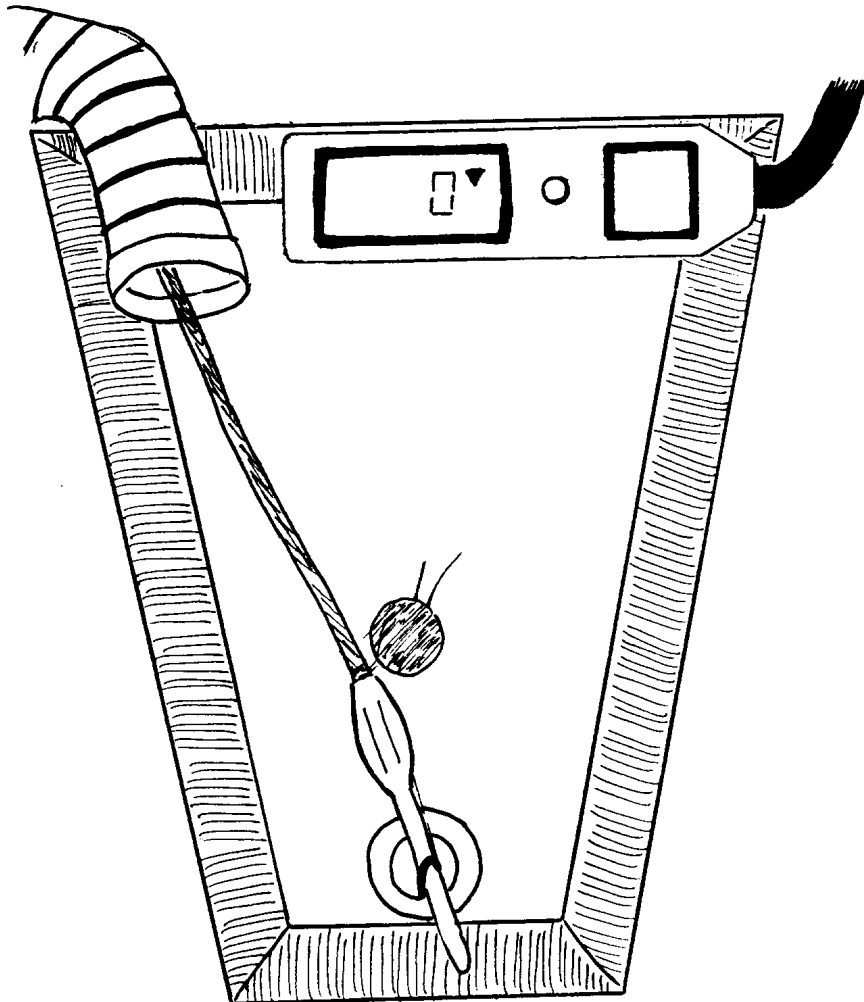

When packing any reserve please also check the following:

- reserve ripcord correct length, free of damage
- 3-ring system ensure the teflon cables are of correct length and undamaged. Check the condition of the velcro attachment for the cutaway pad. Check the rings for damage, deformation and freedom of movement. Check the condition of the loop and grommet on the main risers.
- reserve static line correctly fitted, condition of velcro. Ensure that the RSL release handle is of such shape and size that it cannot jam the 3-ring system.

Cutter replacement - Cable connections

Never, ever disconnect any of the cables in Cypres.

Once Cypres has fired it must be returned to Airtec or another authorized service agent for replacement of the release unit. We guarantee a one day turnround for this service.

This is not necessary if the unit is equipped with the new easy to replace cutter. Please refer to chapter 6.3 in our User's Guide.

The following instructions are supplied with every Cypres.



Information for Riggers and Packers How to replace the NEW CYPRES cutter

03/95

The cutter replacement after a CYPRES activation has become much simpler since the advent of the updated CYPRES cutter. We would ask you nevertheless to adhere strictly to the following instruction. Thank you very much.

What is an "updated cutter"?

The new, easy to replace cutter has a connector plug incorporated into the release element cable (cutter cable).

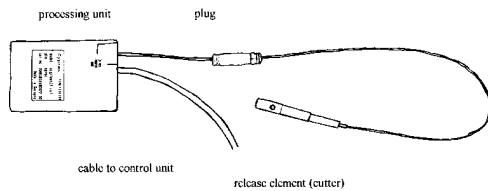

If there is/are no connector plug/s the whole Cypres must be returned to Airtec or SSK Ind. (US) after a firing. We will do the replacement. **Only** in **special** circumstances, and on request, it may be possible to equip your unfired, old style cutter CYPRES with the new replaceable cutter. We reserve to replace an unfired cutter for ourselves.

Who can do the cutter replacement?

If the CYPRES is equipped with the new cutter any qualified rigger or packer may do the replacement.

How is the cutter replaced?

- 1 Unpack the reserve and remove the CYPRES.
- 2 Remove the CYPRES battery.
- 3 Disengage the plug connection.
Take the plug connection in both hands and pull apart (it is quite normal to need some force to do this).

Airtec GmbH Mittelstr. 69, 33181 Wunnenberg, Germany Tel +49 2953 8010. Fax: +49 2953 1293

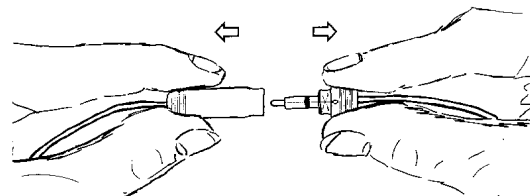

Again: **Do not pull or bend the cables**

- 1 Connect the new cutter.
Ensure that both parts are correctly aligned (do not try to force at an angle).
An audible 'click' indicates a proper connection.

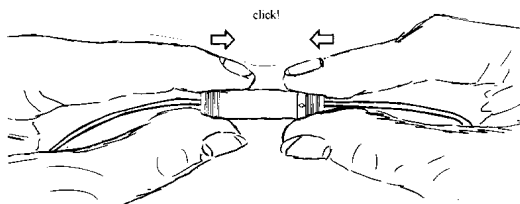

Again: **Ensure both parts of the plug are correctly aligned**
Do not bend the cables where they leave the plug

- 2 Insert the CYPRES battery.
- 3 Serviceability Check

Having fitted the cutter unit, simply switch the CYPRES on. During the self test CYPRES checks if the cutter is properly connected and a satisfactory self test denotes that all is well.

What to do with an old cutter?

The fired cutter must be returned to Airtec or SSK Ind. (US). The **activation form** which comes with every replacement cutter must be returned to Airtec or SSK Ind. (US) as well. Thank you for your help.

Airtec GmbH Mittelstr. 69, 33181 Wunnenberg, Germany Tel +49 2953 8010. Fax +49 2953 1293

Battery replacement

Before replacing batteries, please read the detailed information in the User's Guide section.

It is most important to remember that these batteries are extremely sensitive to short circuits which will render them unusable. Please use extreme caution when handling the batteries or replacing them. Even a short circuit which lasts for just fractions of a second will render the batteries unserviceable.

The battery must be replaced after 2 years **or** 500 jumps **or** if the low battery error code is encountered during self-test whatever comes first.

Rigger's Guide - Installation Special

When installing Cypres it is vital to ensure that installation is carried out in accordance with the instructions in this manual and any written instructions issued by the rig manufacturer.

Contents:	page
Vector I	44
Vector II	48
Chaser (representing Racer, Racer Elite, Chaser, Sprint, Tear Drop and some other 2-pin Pop Tops)	49
One Pin Tear Drop	51
Javelin	52
Talon	53
Atom	54
Jaguar and Mini Jaguar	55
LOR II - special note	56
Ultra	57
Invader	58
Vulcan	59
Mini Hawk	60
Combination Tandem	61
Sweethog	62
EOS	63
Top Flyer V	65
Top Flyer VI	66
Pitt III (for round reserve)	67
Warp III (for round reserve)	68
Centaurus	70
Wonderhog	71

ACE	73
Naro	74
Excaliber	75
Innovator II	76
Swift	77
Dual Hawk Tandem	78
Vector Tandem	81
Galaxy Tandem	82
Zerox	83
Swift II	84
Eclipse	85
Vector III	86
Dolphin	87
Prestige	88
Sidewinder	89
Orion	90
Questionnaire concerning systems not included above	

NOTE: All directions (i.e. left/right, top/bottom etc.) in the Installation Special section are as seen in the diagrams.

If installation into a system is contemplated which has not been described on the following pages, it is mandatory to contact Airtec. See also last page of this special part.

Vector I

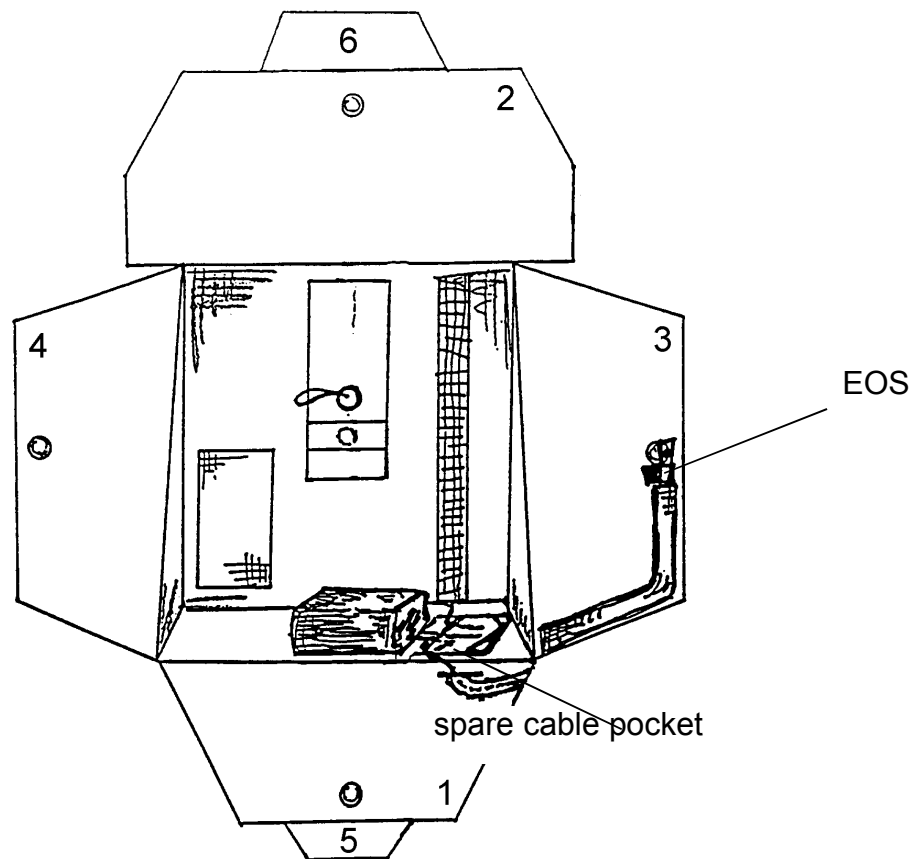

- Position processing unit so that the spare cable pocket is to the right.
- The release unit cable should be routed via flaps 1 and 3. A small passage hole must be made in flap 1, the position of which can be determined by closing flaps 1 and 3 as if the rig were packed. It is then easy to see where the cable should go, between 1 and 3cm from the right hand edge of the flap. Make the hole 1cm long using a hot knife. The cable housing should be glued and sewn to the under surface of flap 3.
- Align the release unit (EOS) so that it lies parallel to the long axis of the container, ensuring that the loop hole is in line with the right hand inner edge of the grommet.
- The cable housing for the control unit can be glued to the bottom of the container or alternatively, the cable can be routed through the double fabric layer of the bottom of the container, in which case a small 1.5cm passage hole must be cut with a hot knife.

Vector I (continued)

If the cable is routed inside the double skin of the container, it must be parallel and next to the edge of the loop reinforcement plates. Secure the cable with a couple of loose tacks which will prevent sideways movement whilst allowing the cable to flex.

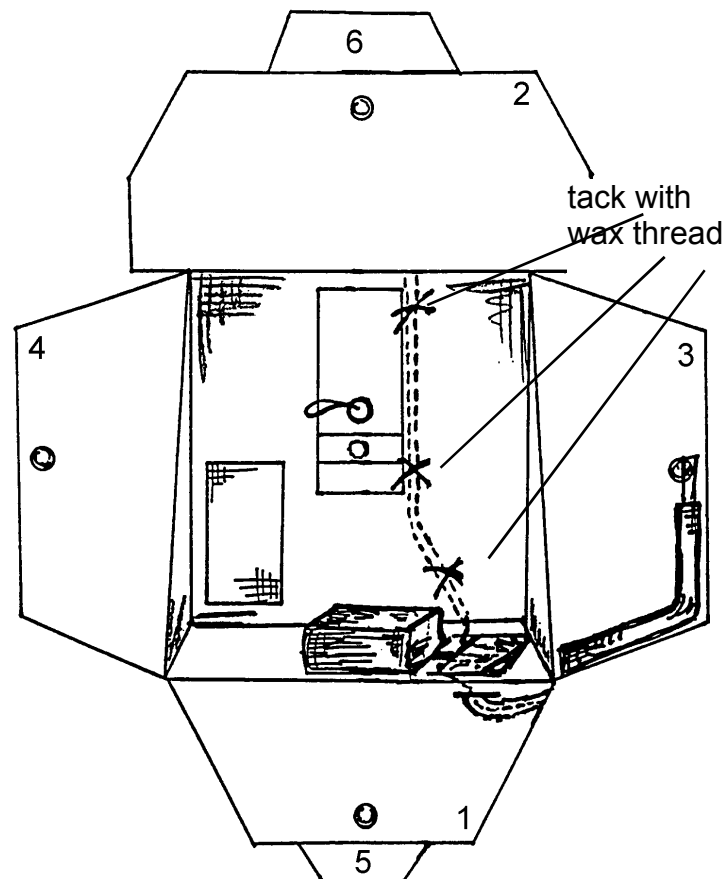

There is no need to make a hole for the cable at the top of the container. It passes easily between the two nylon layers at the back (by flap 5).

Vector I (continued)

Positioning of the release unit

Ensure there is no gap between the cable housing and the elasticated release unit housing.

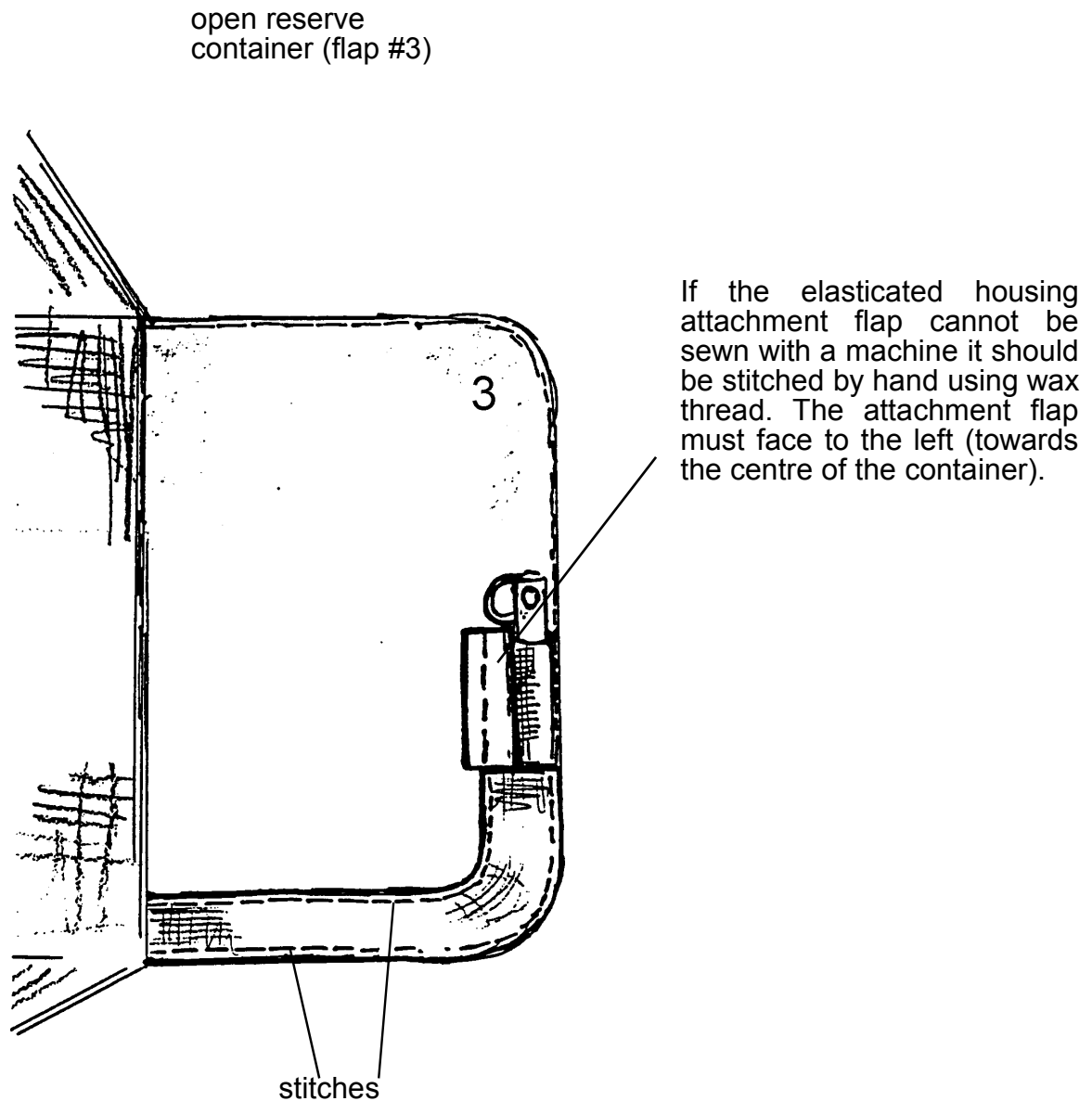

Ensure the two rows of stitching are at least 1cm apart or there may be difficulty pushing the release unit round the corner of the flap. The outer row of stitching should run along the middle of the edge binding tape. Please follow the diagram exactly.

Vector I (continued)

Positioning of the control unit

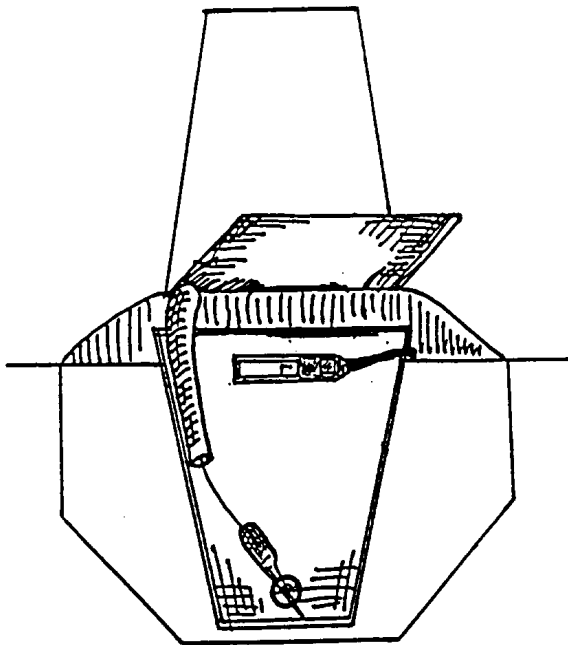

The control unit should be mounted at 90° to the container's vertical axis. In older systems the ripcord housing may have to be moved to the far left side of the flap.

Attach the control unit by using either the nylon fixing ties or the transparent pocket. Velcro is not recommended on Vector rigs (see pages 16 and 17).

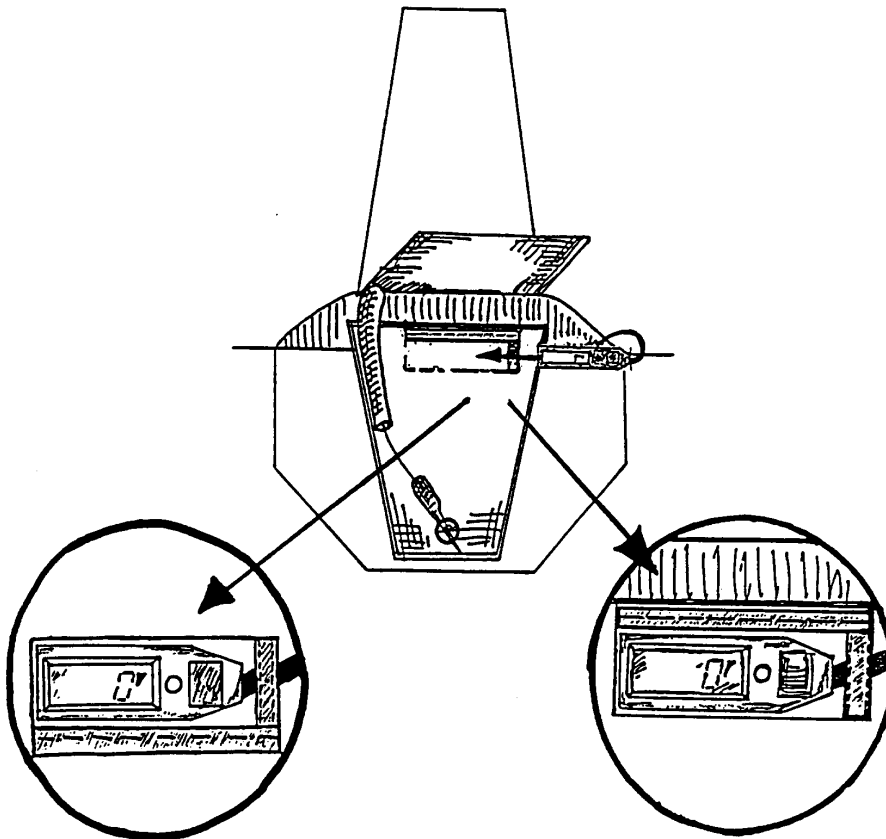

IMPORTANT:
Use only original silicone impregnated Cypres loops.

Vector II

The release unit should be mounted on the inner surface of flap 1.

Please refer to Vector I section for details of attaching the control unit and various housings.

Use only original silicone impregnated Cypres loops.

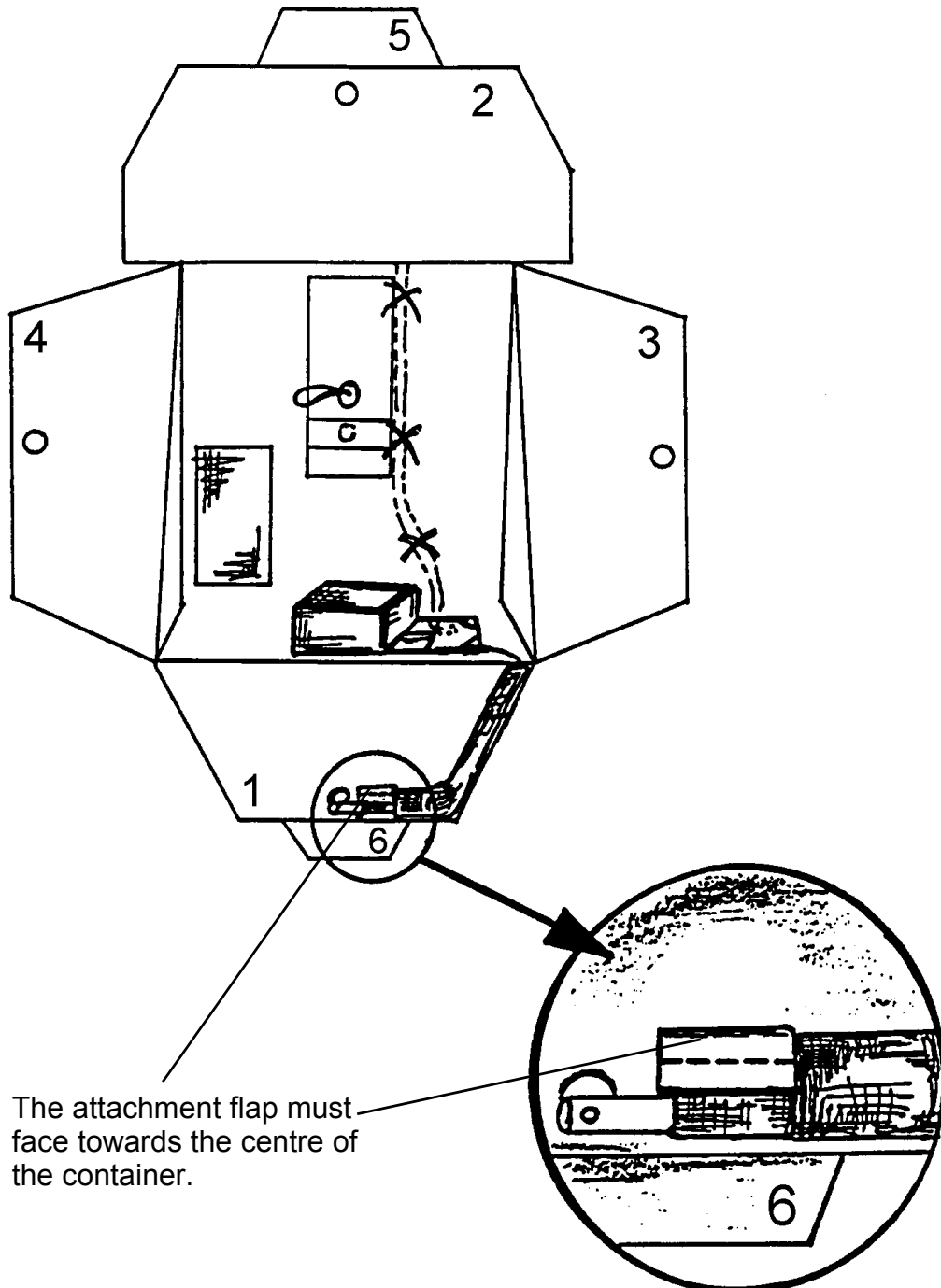

The attachment flap must face towards the centre of the container.

IMPORTANT:

You must use an original Vector II reserve pilot chute (with a strong spring and a broad, rigid disc) with a Vector II rig.

Chaser (representing Racer, Racer Elite, Chaser, Sprint, Teardrop and other two-pin Pop Tops)

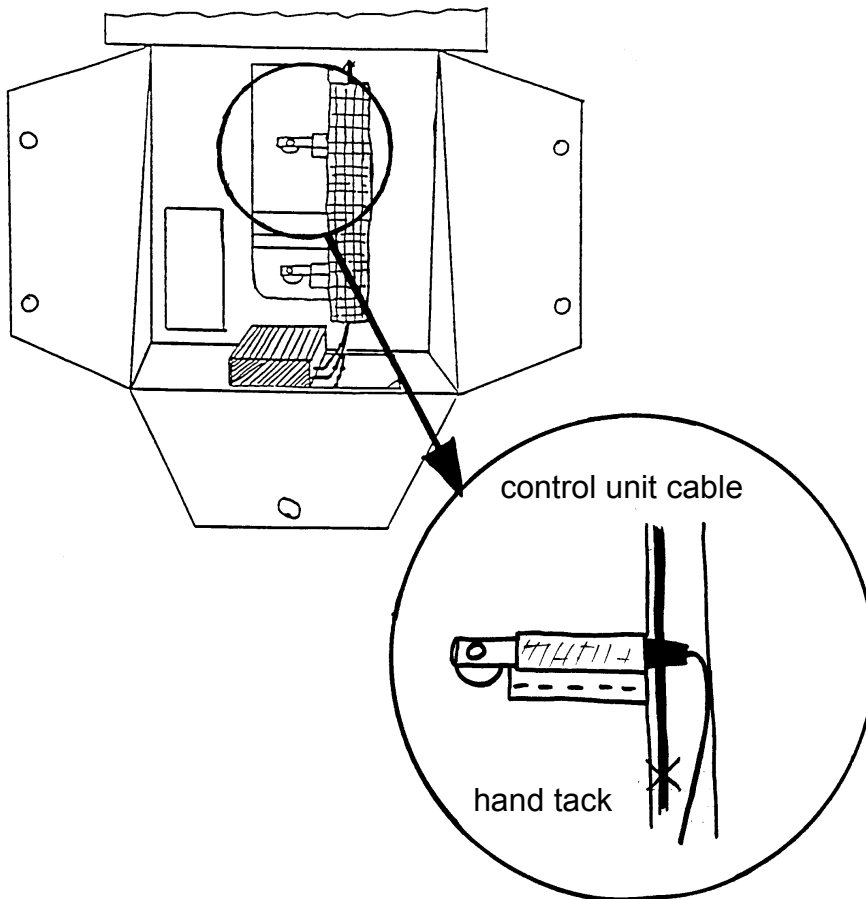

Sew the release unit elasticated housings to the bottom of the container with the attachment flaps facing towards the processing unit.

- Position processing unit so that the spare cable pocket is to the right.
- In a 2-pin Pop Top installation the control unit cable should be positioned hard against the edge of the stiffener plate so that it lies underneath the black plastic tapered end(s) of the release unit(s). This provides support for the unit (s), particularly if the stiffener plate is curved. If necessary secure the cable in the desired position with a couple of hand stitches (see diagram).
- Cut 2 small holes in the cable housing for the release elements to pass through.
- Cut a small hole in the neck area of the container through which the control unit must be pushed before being positioned on the flap.

Chaser (continued)

(representing Racer, Racer Elite, Chaser, Sprint, Teardrop and other two-pin Pop Tops)

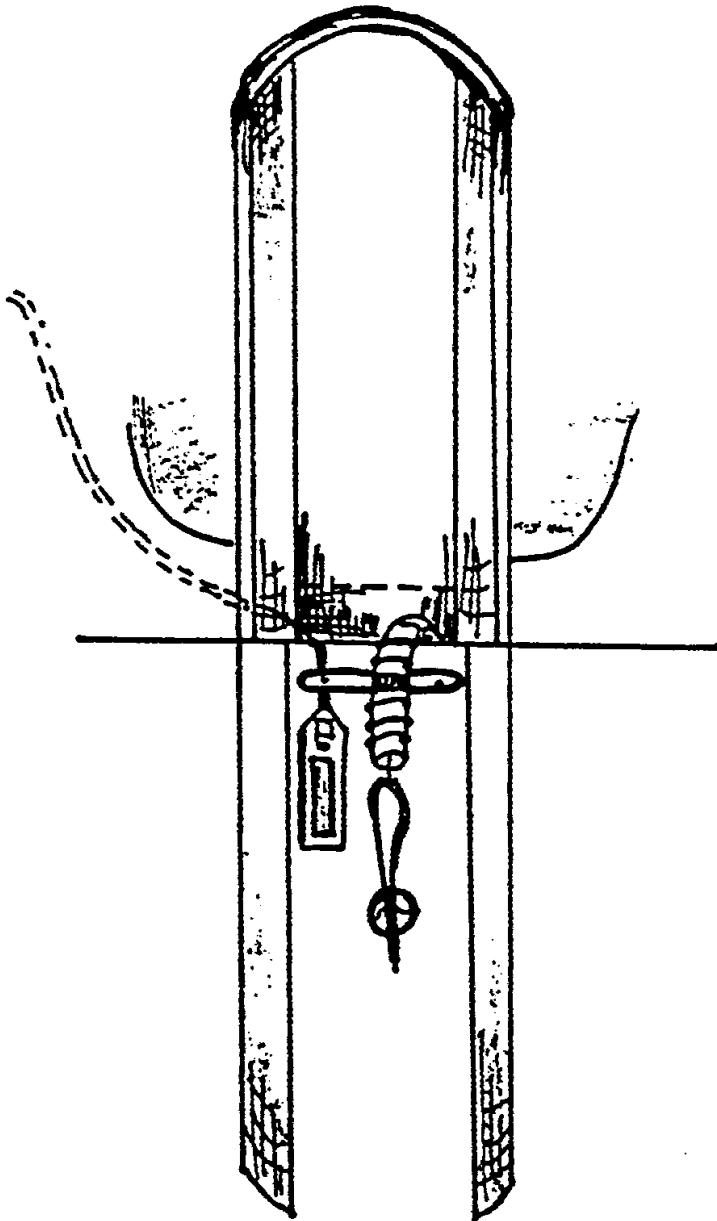

In the new Chaser the control unit should be routed through the existing reserve ripcord housing opening. To do this, it will be necessary to detach the ripcord housing, which must be resecured once the control unit has been routed through the hole.

Position the control unit so that the push button is next to the ripcord housing. You must ensure, however, that there is no contact with the housing, the ripcord or the grommets.

We recommend that the control unit is attached using either the nylon fixing ties or the transparent pocket. The glued velcro method should only be used:

- a) in Pop Top systems where it is impossible to drill or pierce through the reinforcement plate or
- b) in systems where the manufacturer has already incorporated the velcro in the appropriate position as part of a Cypres installation during manufacture.

(see also pages 15-17.)

One Pin Tear Drop

Sew the release unit elasticated housing to the bottom of the container with the attachment flap facing towards the processing unit.

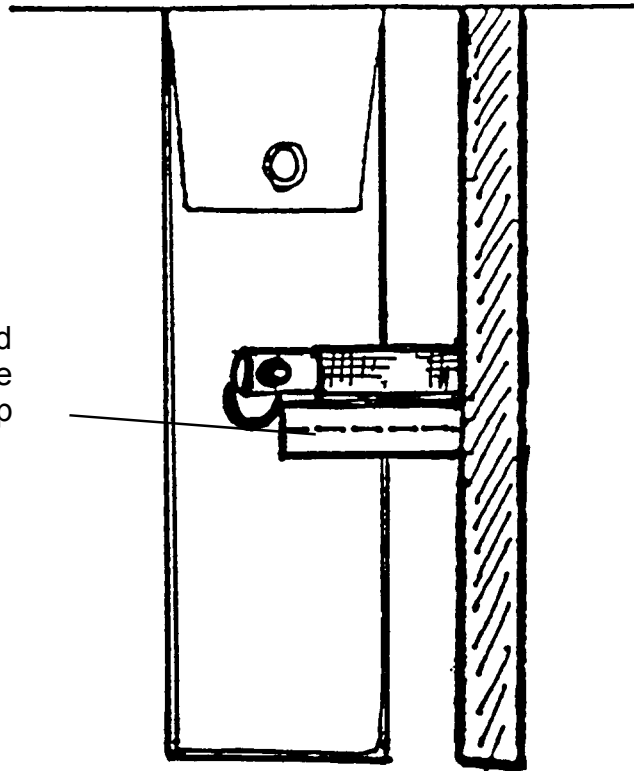

- processing unit as in Racer
- release unit as shown in drawing
- control unit as in Racer

Use only original Cypres loop material.

To protect the integrity of the fingertrapped or spliced section of the polyamide, loops for 1-pin Pop Top rigs should not be silicone impregnated.

Javelin

The diagram shows the installation of the complete system.

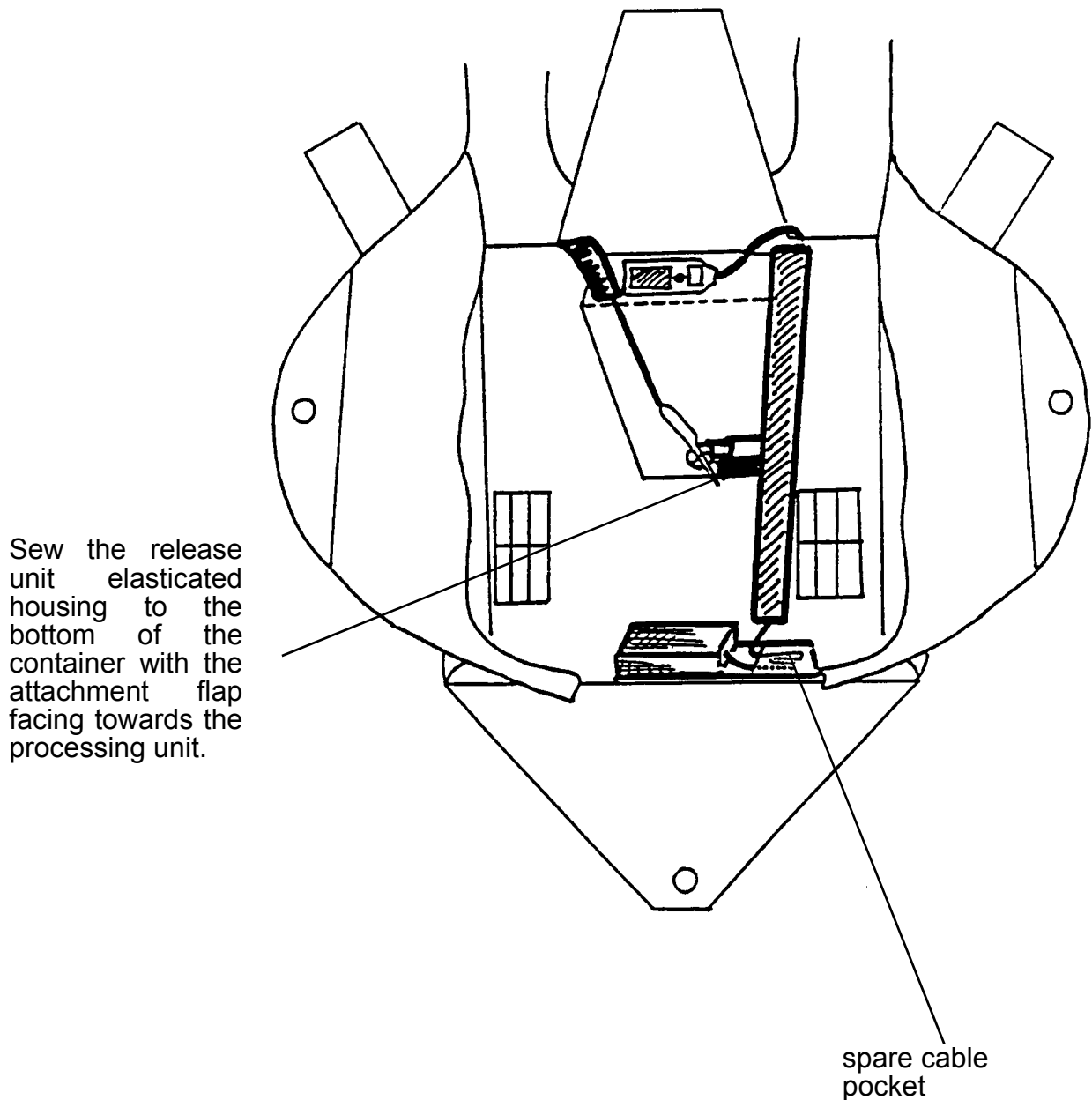

- Position processing unit so that the spare cable pocket is to the right.
- Position release unit perpendicular to long axis of container.
- Route control unit cable direct to the top right hand corner of rig.
- Position control unit on top reserve flap to the right of ripcord housing.
- Attach the control unit by using either the nylon fixing ties or the transparent pocket. The velcro may also be used but the end result is less elegant.

Talon

Where Cypres fittings have been incorporated by the manufacturer the control unit cable housing is routed underneath the right riser cover flap.

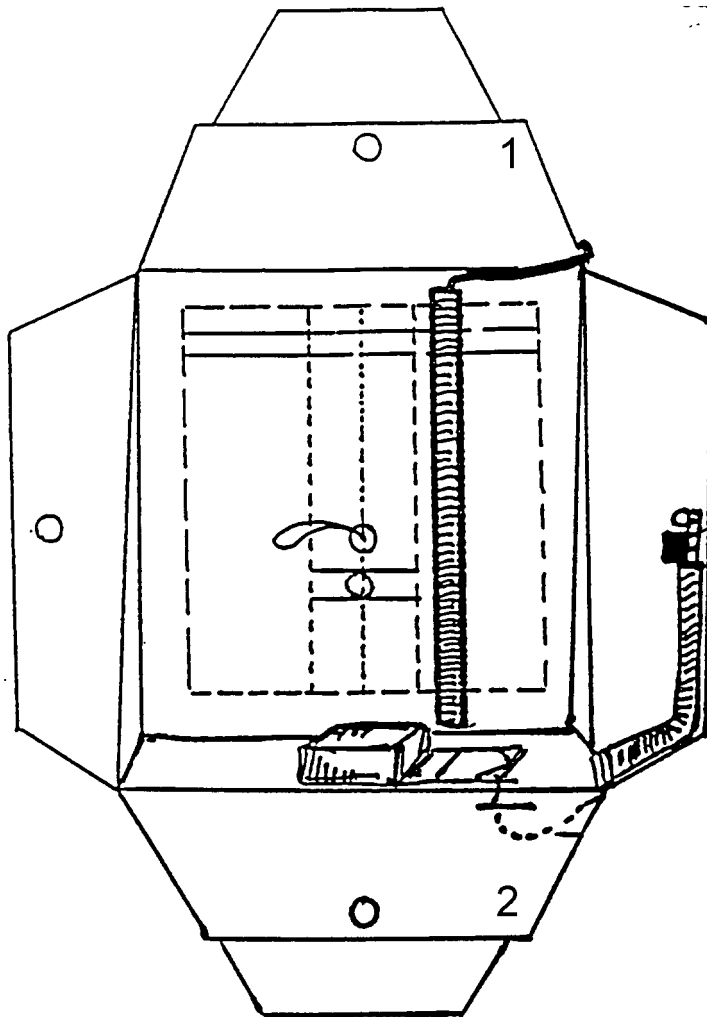

If the elasticated housing attachment flap cannot be sewn with a machine it should be stitched by hand using wax thread. The attachment flap must face to the left (towards the centre of the container).

- Position processing unit so that the spare cable pocket is to the right.
- The release unit cable should be routed via flap 2 and 3. A small passage hole must be made in flap 2, the position of which can be determined by closing flaps 1 and 3 as if the rig were packed. It is then easy to see where the cable should go, between 1 and 3cm from the right hand edge of the flap. Make the hole 1cm long using a hot knife. The cable housing should be glued and sewn to the under surface of flap 3.
- Align the release unit (EOS) so that it lies parallel to the long axis of the container, ensuring that the loop hole is in line with the right hand inner edge of the grommet.
- If there are 2 reserve riser cover flaps built into the bottom of the container, the control unit cable should be positioned under the right hand flap. If no flaps are provided, the cable should be routed through the double fabric layer of the bottom of the container. The control unit can then be attached using either the nylon fixing ties or the transparent pocket. The velcro may also be used but the end result is less elegant. (see also pages 45-47.)

Atom

same as Vector I, **except:**

- The order of flaps 3 and 4 can be reversed compared with the order normally used by most manufacturers. In this case the cutter has to be mounted on flap #4 (the right flap), and this flap has to be closed before the left one. The closing sequence is then 1 - 2 - 4 - 3 - 5 - 6. It is useful to change the numbers on the side flaps, this will help other riggers/reservepackers to close the container in the correct closing sequence.
How ever the side flaps are numbered, the release element has to be mounted on the right reserve flap which then closes before the left one.
- Due to the narrowness of the reserve top flaps, the control unit should be attached parallel to the long axis of the container using the nylon fixing ties. This will require drilling of the plate. Use of the transparent pocket or velcro will cause unsightly bulging.
- The rig manufacturer installs the cutter in new rigs under flap 1.

Jaguar and Mini Jaguar

same as Vector I, **except:**

- Older Jaguar rigs still have "intermediate" flaps.
- The order of flaps 3 and 4 is reversed compared with the order normally used by most manufacturers. Thus the cutter is mounted on flap #4 (the right flap), and this flap has to be closed before the left one. The closing sequence is therefore 1 - 2 - 4 - 3 - 5 - 6. It is useful to change the numbers on the side flaps, this will help other riggers/reservepackers to close the container in the correct closing sequence.
- **We stress the fact that the cutter must be mounted onto the first reserve flap above the pilot chute in all Jaguar and Mini Jaguar.**
- Due to the narrowness of the reserve top flaps, the control unit should be attached parallel to the long axis of the container using the nylon fixing ties. This will require drilling of the plate. Use of the transparent pocket or velcro will cause unsightly bulging.

Important note on use of Cypres with LOR II from Parachutes de France (e.g. in the Atom, Campus and Galaxy Tandem)

The LOR II system uses 2 closing loops and 2 pins through a single grommet. Both loops run through a single CYPRES cutter. This requires the use of special (thinner) LOR II loops, provided exclusively by Parachutes de France.

The principle is that in the event of an RSL-activated reserve deployment, the reserve cannot open until both main risers have positively separated from the harness.

WARNING: Never use two regular CYPRES loops for LOR II equipped Pdf containers.

Ultra

see Vector I

Ultra systems manufactured in 1992 or later and having a Vector II reserve pilot chute can be treated in the same way as Vector II rigs.

In older systems flap 4 in the Ultra was flap 3 in the Vector.
Since June 1991 flap numbering has been the same in both systems.

Invader

see Vector I

Vulcan

see Vector I

Mini Hawk

If the elasticated housing attachment flaps cannot be sewn with a machine they should be stitched by hand using wax thread. The attachment flaps must face towards the centre of the container.

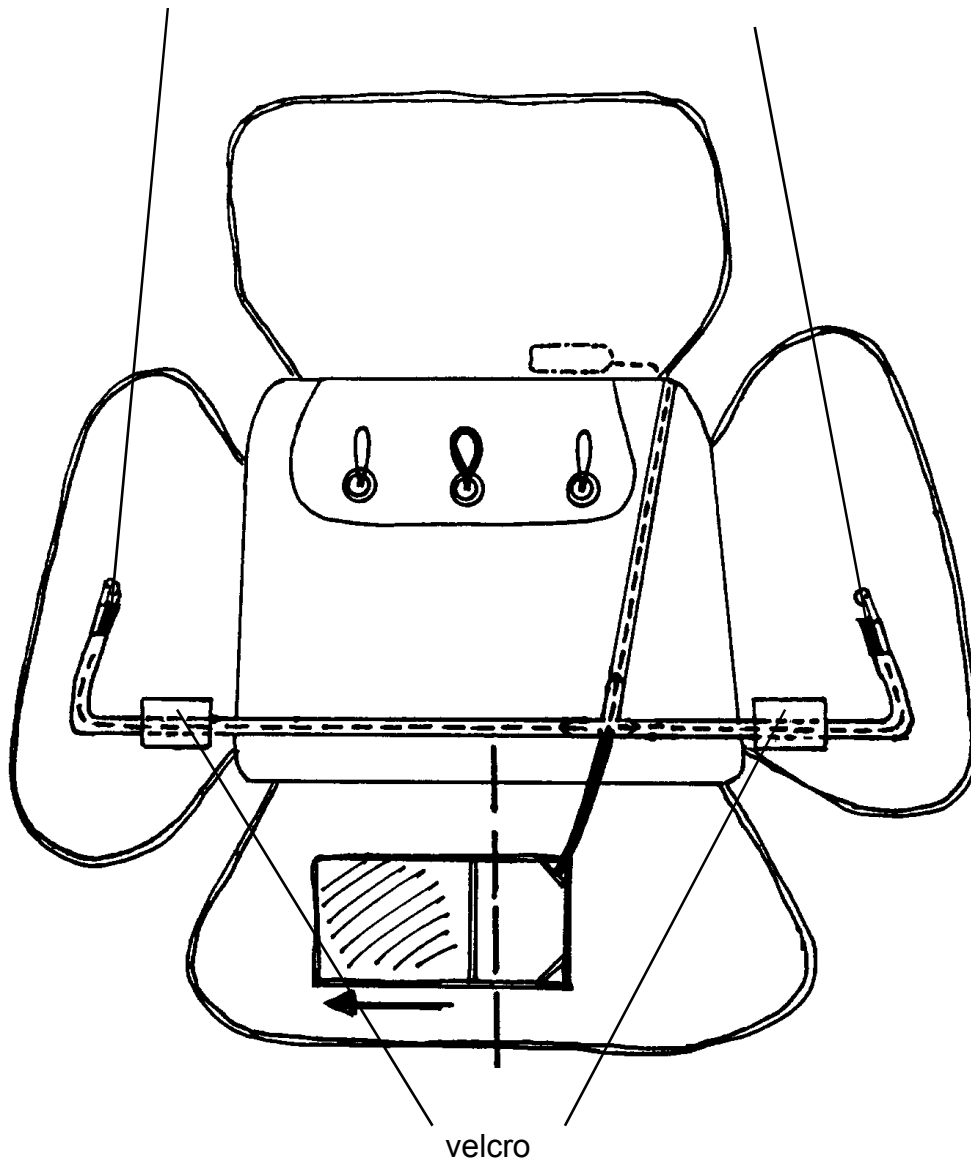

- To enable the release unit cables to reach both side flaps, the pocket for the processing unit should be mounted on the partition wall 6cm left of centre.
- Route the release unit cable housings on the bottom of the container close to the partition wall. The correct routing for the cable housings is underneath the velcro patches on the side flaps. It is therefore necessary to remove the velcro patches and reattach them on top of the housing. The cable housing should be sewn in position in addition to the use of its self adhesive backing.
- Route the control unit cable direct to the right hand edge of the top flap. The control unit can then be attached on the outside of the flap using either the nylon fixing ties or the transparent pocket.

Combination Tandem

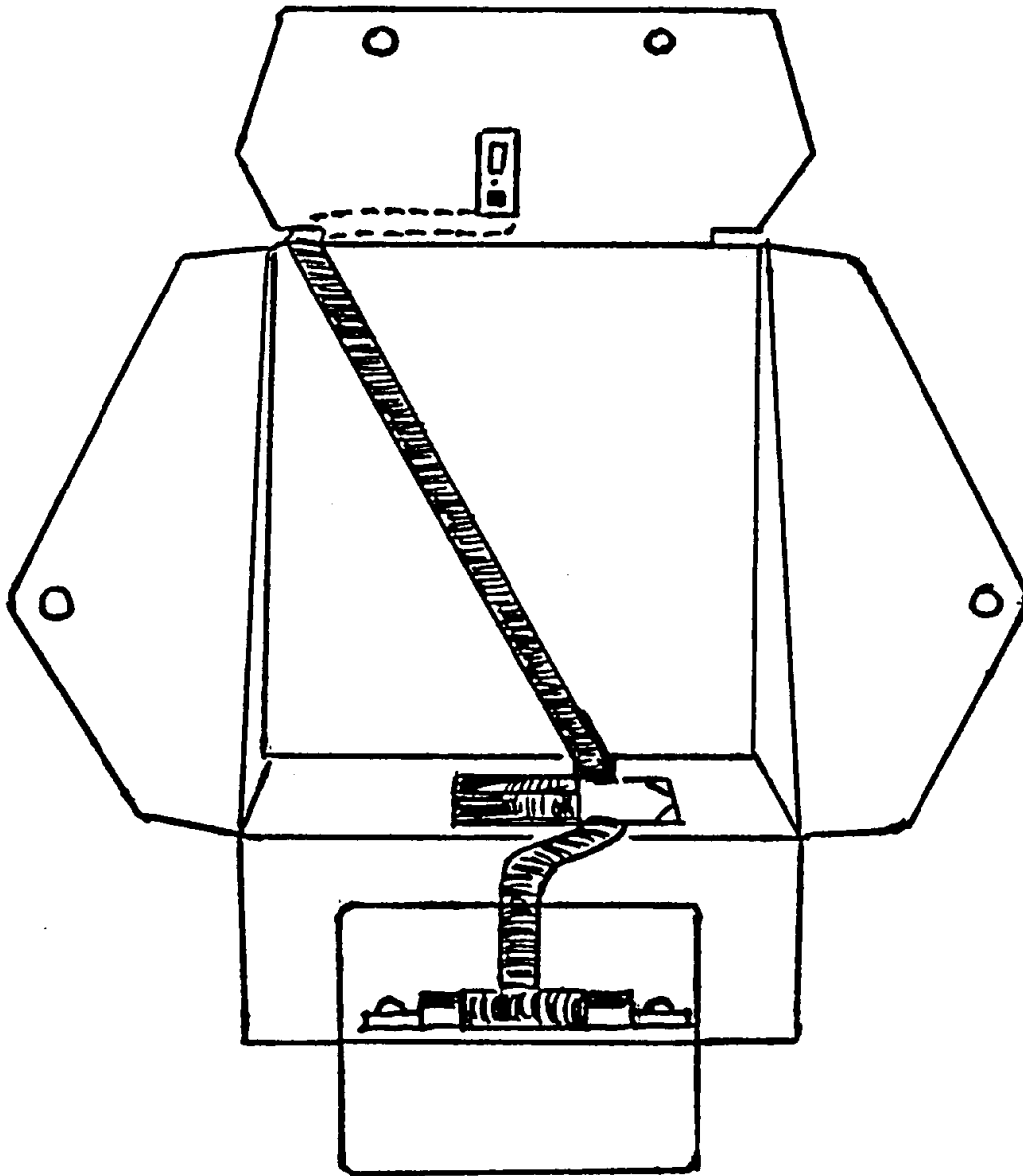

If the elasticated housing attachment flaps cannot be sewn with a machine they should be stitched by hand using wax thread. The attachment flaps must face towards the centre of the container.

- Position the processing unit so that the spare cable pocket is to the right.
- Fix the self adhesive control unit housing as shown in the diagram, routing it directly to the left hand edge of the top flap. The control unit can then be attached on the outside of the flap using either the nylon fixing ties or the transparent pocket.
- The release unit housing is attached to the bottom flap in the form of an inverted "T" underneath the kicker flap.
- When packed, the release units should sit directly on top of the pilot chute.

Sweethog

same as Vector II

EOS

The diagram shows cover flap without the outside fabric cover

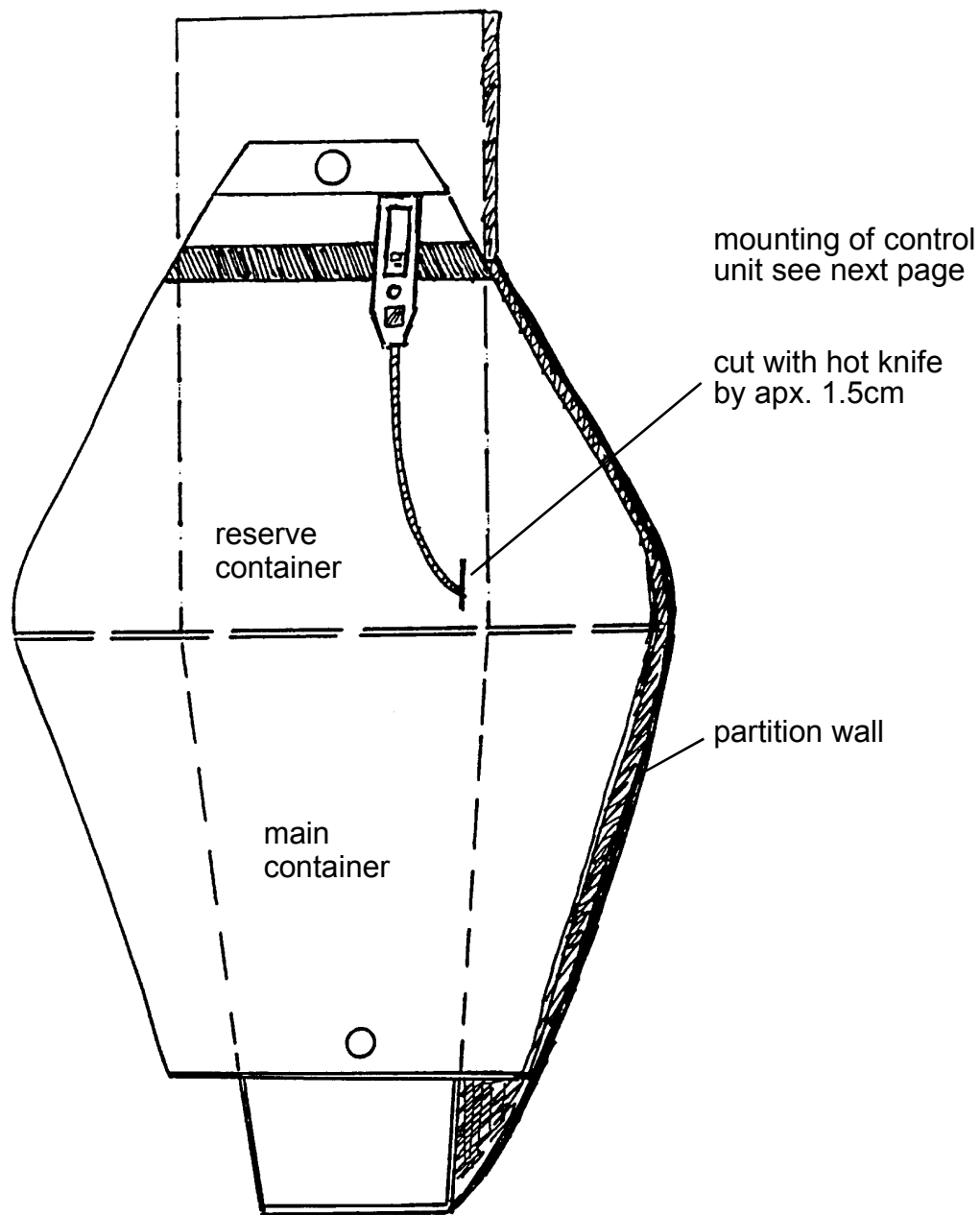

- Installation of processing and release unit as for Vector I.
- Using a hot knife make a 1.5cm cut in the underside of the double layered cover flap close to the partition wall. The control unit should be pushed through this hole and attached to the elastic strap using the fixing ties. Ensure that the ties are knotted firmly whilst allowing some freedom of movement for the control unit.

EOS (continued)

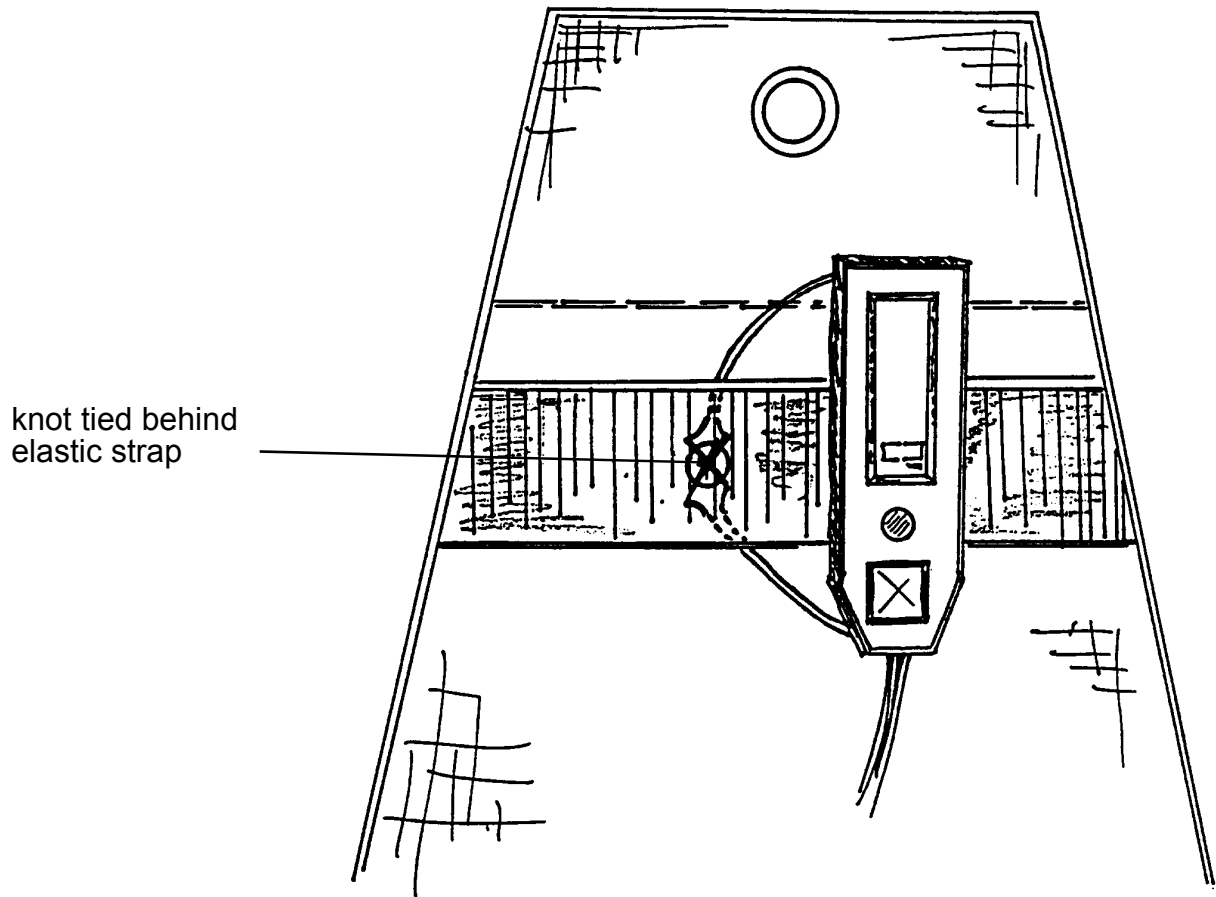

- To activate Cypres the control unit is simply extracted from between the double layers of the flap. The nylon fixing ties prevent complete removal, or indeed, the possibility of the control unit vanishing into the bottom of the flap.

Top Flyer V

This diagram shows the installation of the complete system.

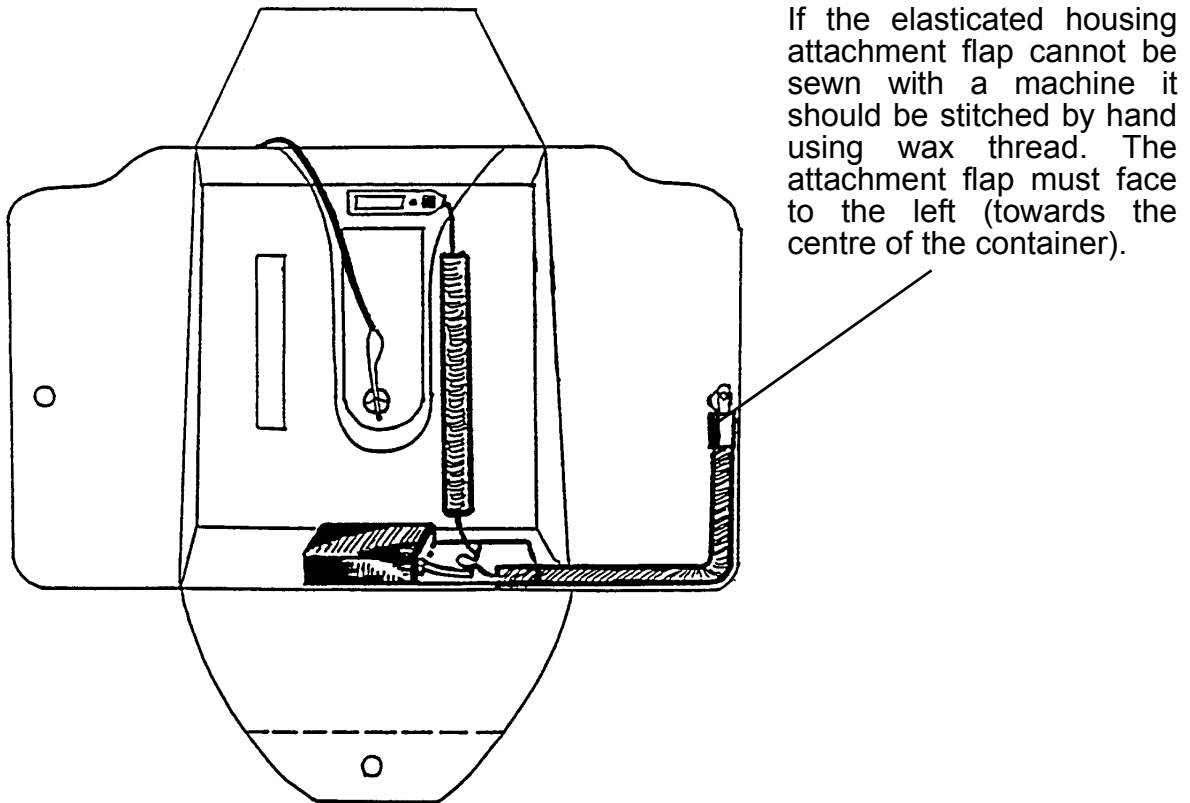

- Position the processing unit so that the spare cable pocket is to the right.
- Align the release unit (EOS) so that it lies parallel to the long axis of the container, ensuring that the loop hole is in line with the right hand inner edge of the grommet.
- Fix the control unit on the outside of the top flap using either the nylon fixing ties or the transparent pocket. The control unit should be aligned as shown in the diagram, i.e. at approximately 90° to the reserve ripcord housing. (see also pages 46-47)

Top Flyer VI

This diagram shows the installation of the complete system.

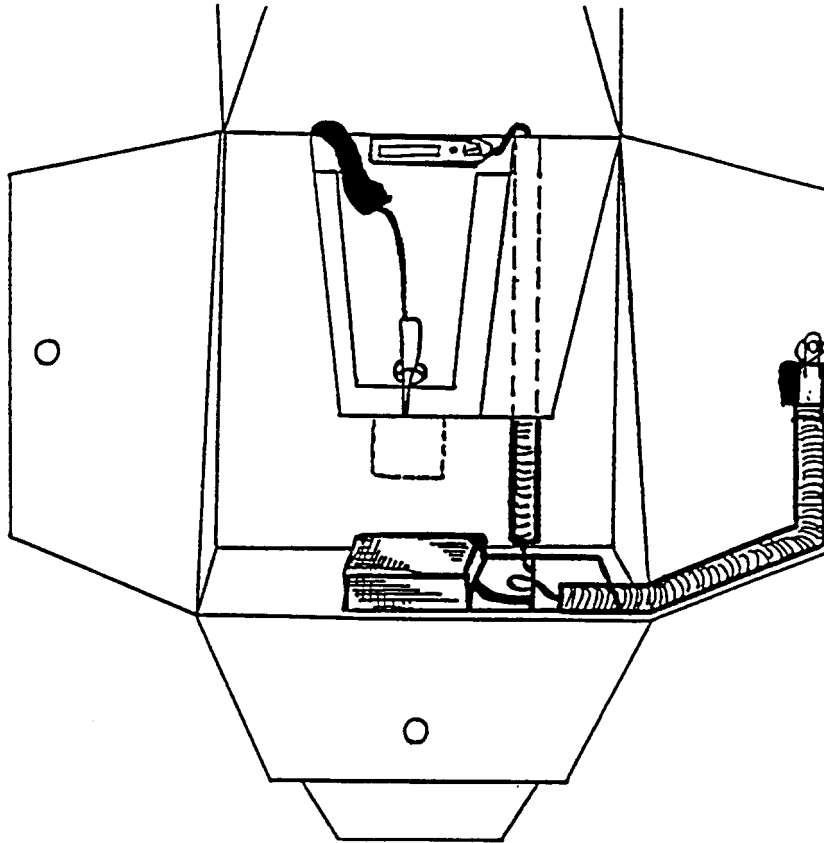

If the elasticated housing attachment flap cannot be sewn with a machine it should be stitched by hand using wax thread. The attachment flap must face to the left (towards the centre of the container).

- Position the processing unit so that the spare cable pocket is to the right.
- Align the release unit (EOS) so that it lies parallel to the long axis of the container, ensuring that the loop hole is in line with the right hand inner edge of the grommet.
- Fix the control unit on the outside of the top flap using either the nylon fixing ties or the transparent pocket. The control unit should be aligned as shown in the diagram, i.e. at approximately 90° to the reserve ripcord housing. (see also pages 46-47)

Top Flyers manufactured in 1992 or later and having a Vector II reserve pilot chute can be treated in the same way as Vector II rigs.

Pitt III (for round reserve)

same as Wonderhog

When the release unit is fitted in the base of a container for a round reserve, cover the release unit(s) with a large piece of adhesive masking tape. Carefully cut a hole (or holes) for the reserve loop(s) to pass through. These holes must be no smaller than a one cent coin to prevent any possibility of masking tape being drawn into the EOS loop hole. The masking tape is used to ensure that there is no possibility of the reserve rigging lines becoming snagged on the release unit.

Warp III with a round reserve

If the elasticated housing attachment flaps cannot be sewn with a machine they should be stitched by hand using wax thread. The attachment flaps must face towards the processing unit.

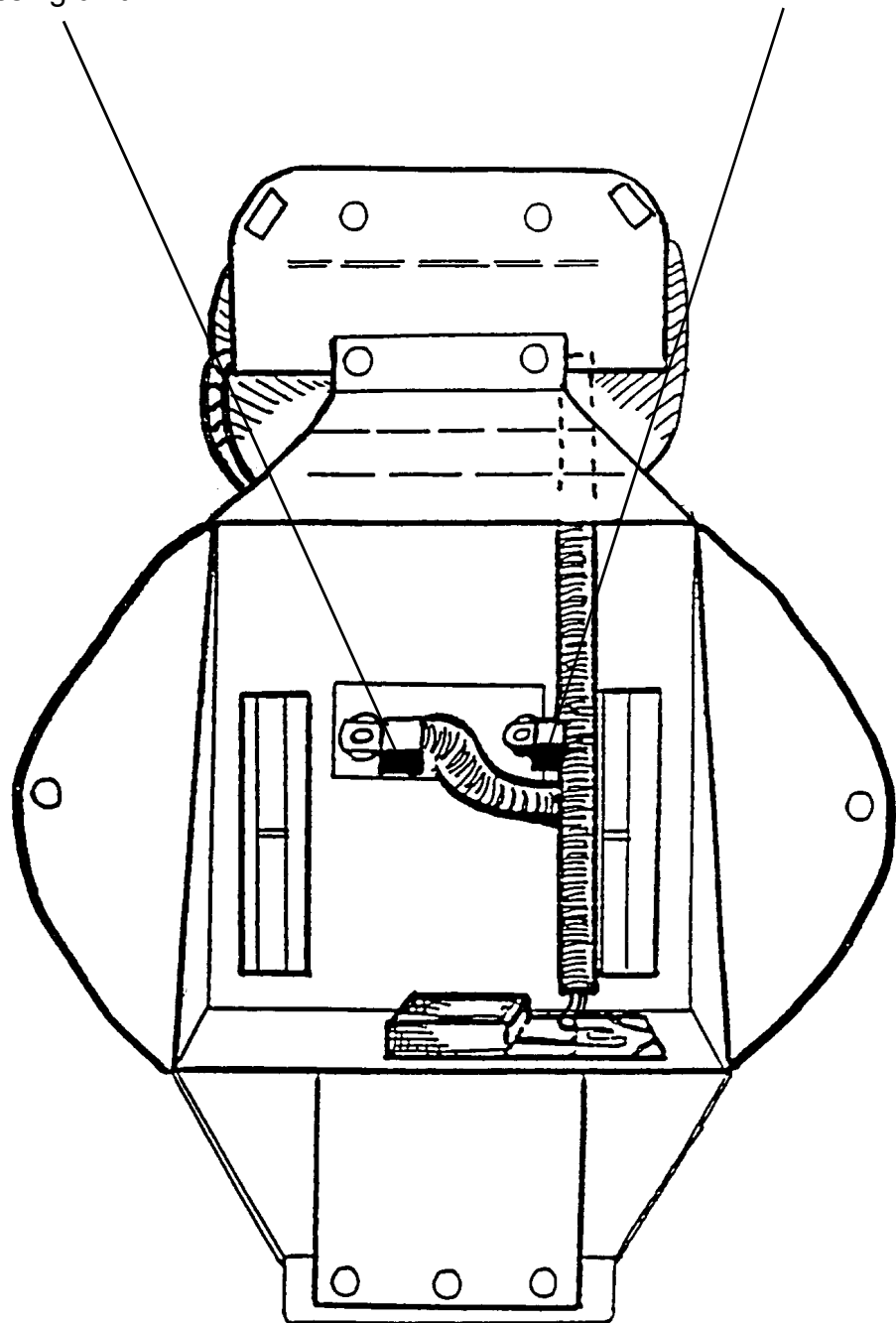

- Position the processing unit so that the spare cable pocket is to the right.
- Position the release elements over the grommets on the bottom of the container, perpendicular to the long axis.
- Route the control unit cable to the top kicker flap as shown in the diagram. Make a passage hole 1cm long using a hot knife.

Warp III (continued)

When the release unit is fitted in the base of a container for a round reserve, cover the release unit(s) with a large piece of adhesive masking tape. Carefully cut a hole (or holes) for the reserve loop (s) to pass through. These holes must be no smaller than a one cent coin to prevent any possibility of masking tape being drawn into the EOS loop hole. The masking tape is used to ensure that there is no possibility of the reserve rigging lines becoming snagged on the release unit.

Route the cable along the underneath of the outer reserve flap using a separate piece of cable housing and make a second 1cm incision in the top pin flap (see diagram).

Attach the control unit to the reserve packing card pouch using the transparent pocket.

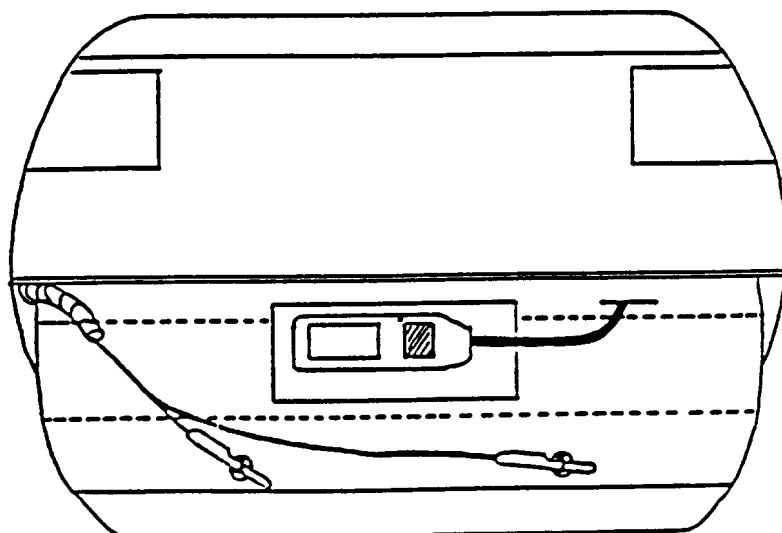
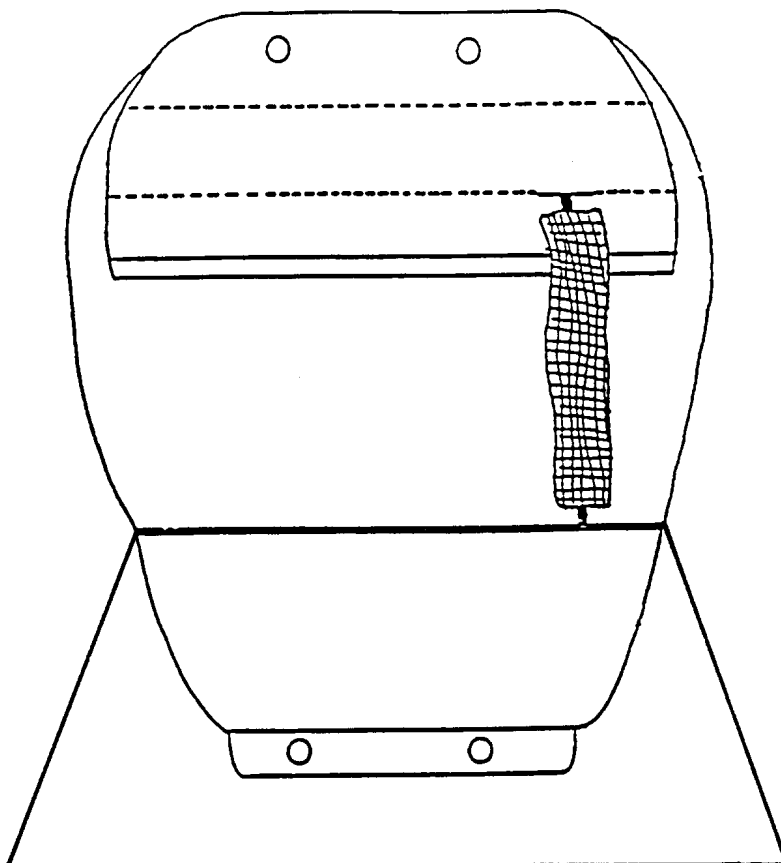

Centaurus

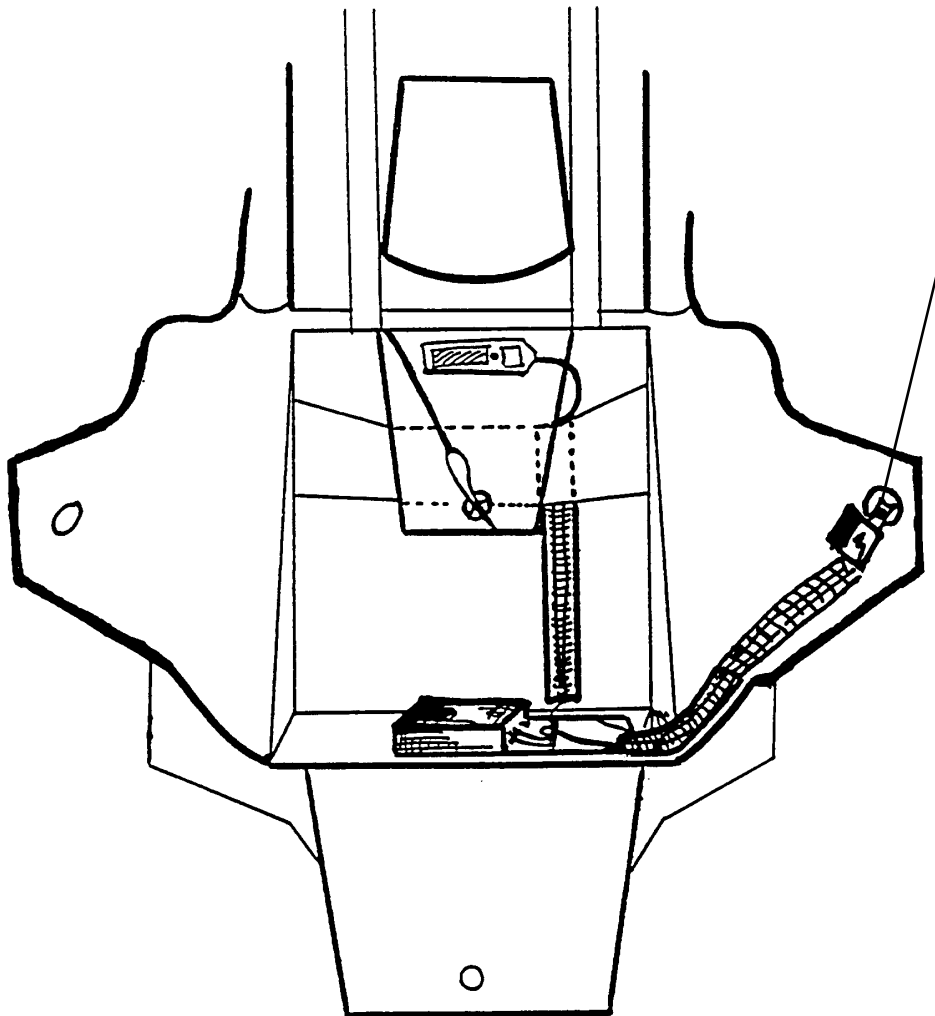

If the elasticated housing attachment flap cannot be sewn with a machine it should be stitched by hand using wax thread. The attachment flap must face to the left (towards the centre of the container).

- Position the processing unit so that the spare cable pocket is to the right.
- Align the release unit (EOS) so that it lies at approximately 45° to the long axis of the container, ensuring that the loop hole is in line with the right hand inner edge of the grommet.
- Fix the control unit on the outside of the top flap using either the nylon fixing ties or the transparent pocket. The control unit should be aligned as shown in the diagram, i.e. at approximately 90° to the reserve ripcord housing. (see also pages 46-47)

Wonderhog

If the elasticated housing attachment flap cannot be sewn with a machine it should be stitched by hand using wax thread. The attachment flap must face to the left (towards the centre of the container).

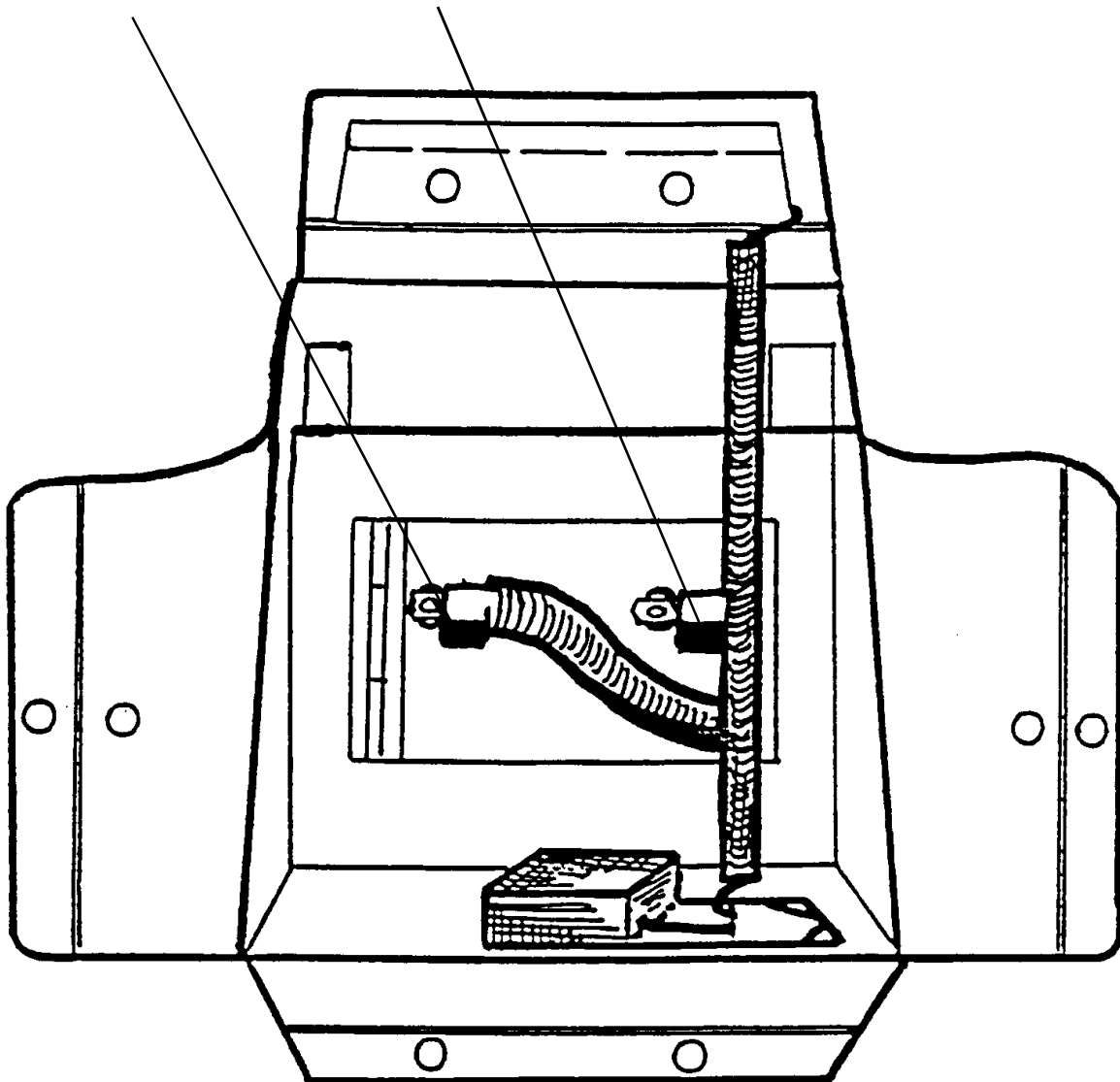

- Position the processing unit so that the spare cable pocket is to the right.
- Position the release elements over the grommets on the bottom of the container, perpendicular to the long axis.
- Fix the self adhesive control unit housing as shown in the diagram, routing it directly to the right hand edge of the top flap.

Wonderhog (continued)

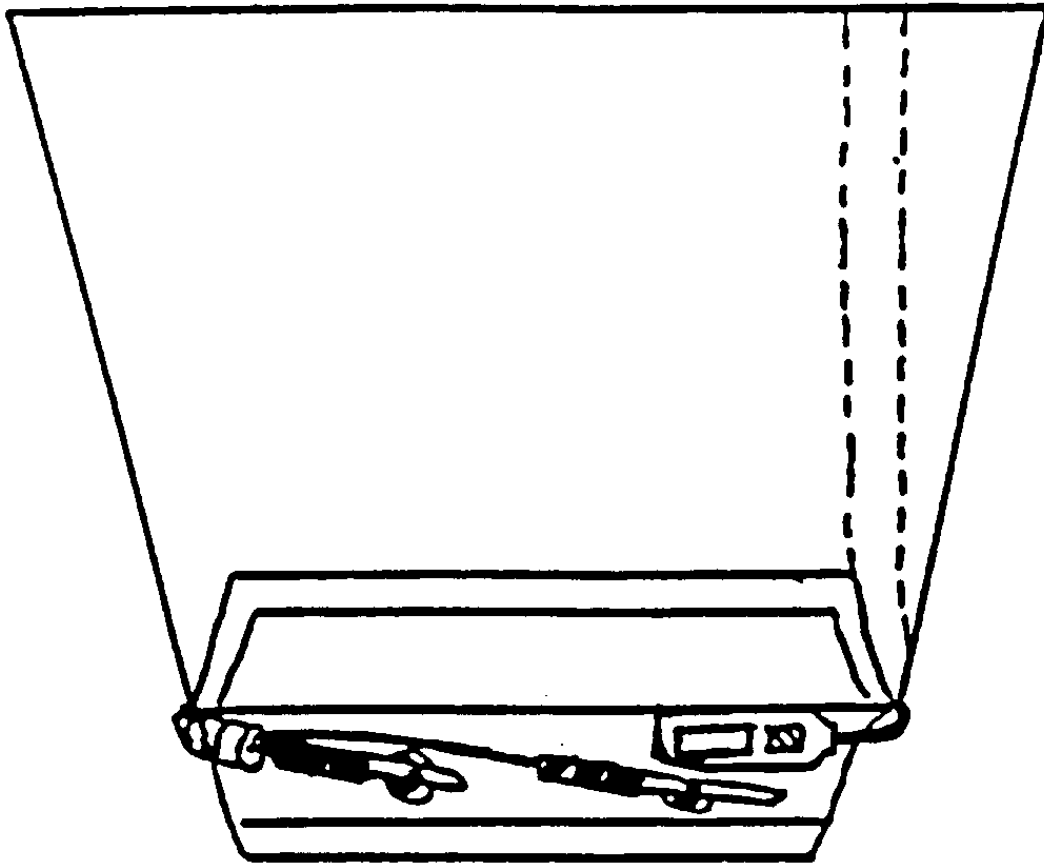

Due to the limited space available and to avoid conflict with the ripcord pins, the control unit must be positioned in the extreme top right corner of the flap. For the same reasons the control unit should be attached using either the nylon fixing ties or the velcro strip.

A C E

see Vector I

NARO

see Vector I

Excaliber

Same as Chaser, **except:**

The alignment of the two release elements is not perpendicular, but apx. 30° to the long axis of the container, and routed from above and below as shown in the diagram.

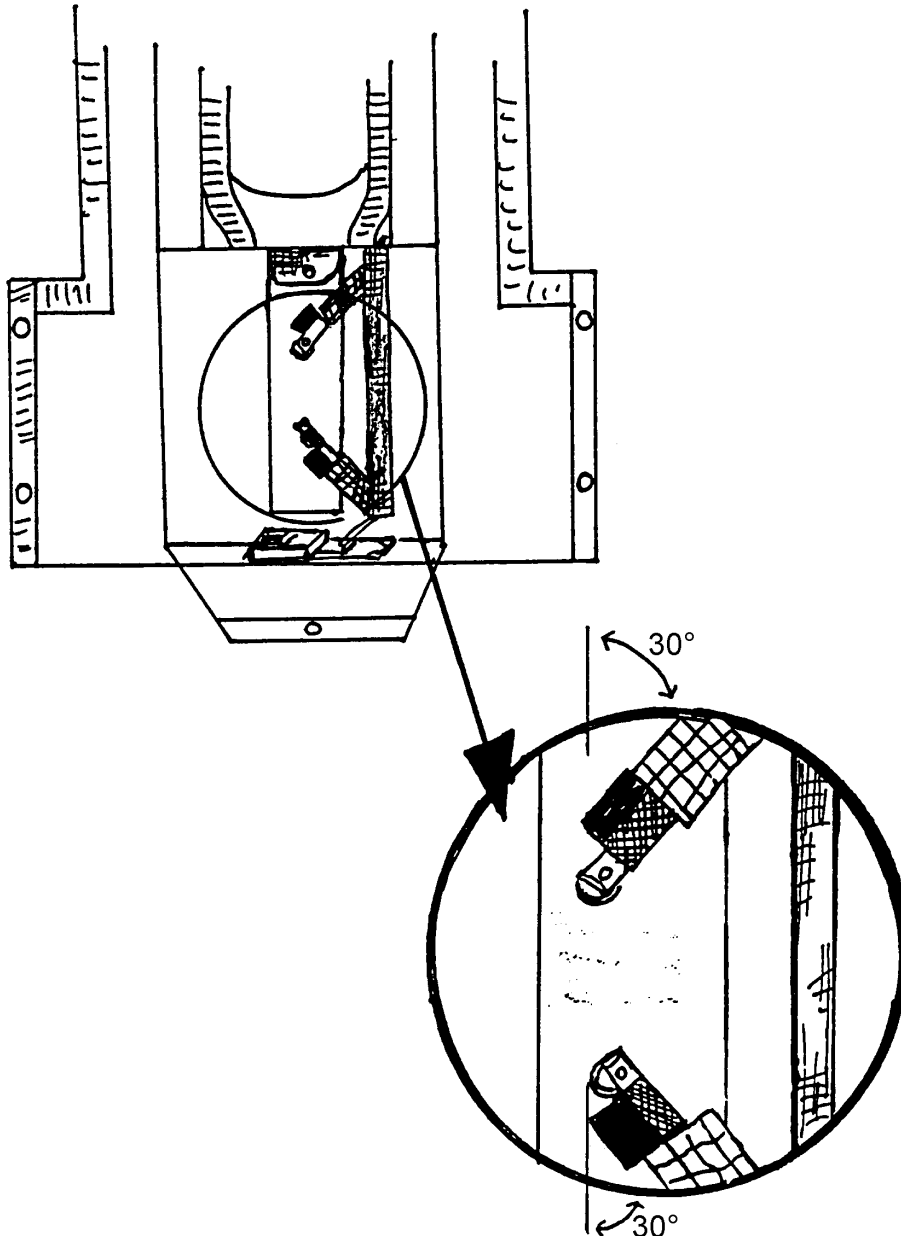

If the elasticated housing attachment flaps cannot be sewn with a machine they should be stitched by hand using wax thread. The attachment flaps must face towards the top and bottom left hand corners of the container respectively.

Innovator II

as Vector I, **except:**

The cable to the release unit is routed underneath rather than through flap 1.

Swift

If the elasticated housing attachment flaps cannot be sewn with a machine they should be stitched by hand using wax thread. The attachment flaps must face to the left (towards the centre of the container).

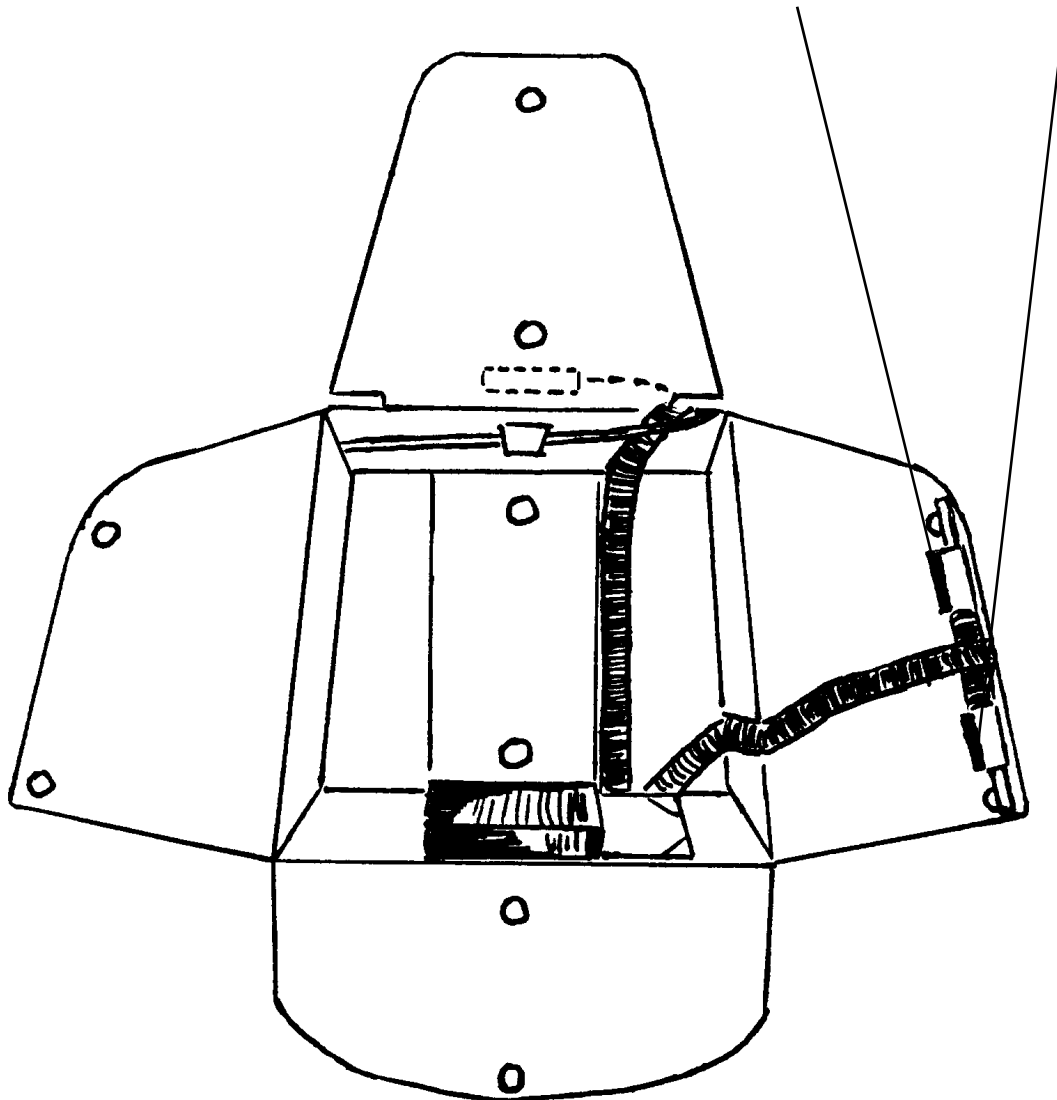

- Position the processing unit so that the spare cable pocket is to the right.
- Route the control unit cable housing directly to the top flap ensuring that it passes underneath the cutaway cable housing.
- Fix the control unit on the outside of the top flap using either the nylon fixing ties or the transparent pocket. The control unit should be aligned as shown in the diagram, i.e. at approximately 90° to the reserve ripcord housing.
- The release unit housing is attached to the right hand flap in the form of a "T".

Dual Hawk Tandem

If the elasticated housing attachment flaps cannot be sewn with a machine they should be stitched by hand using wax thread. The attachment flaps must face towards the centre of the container.

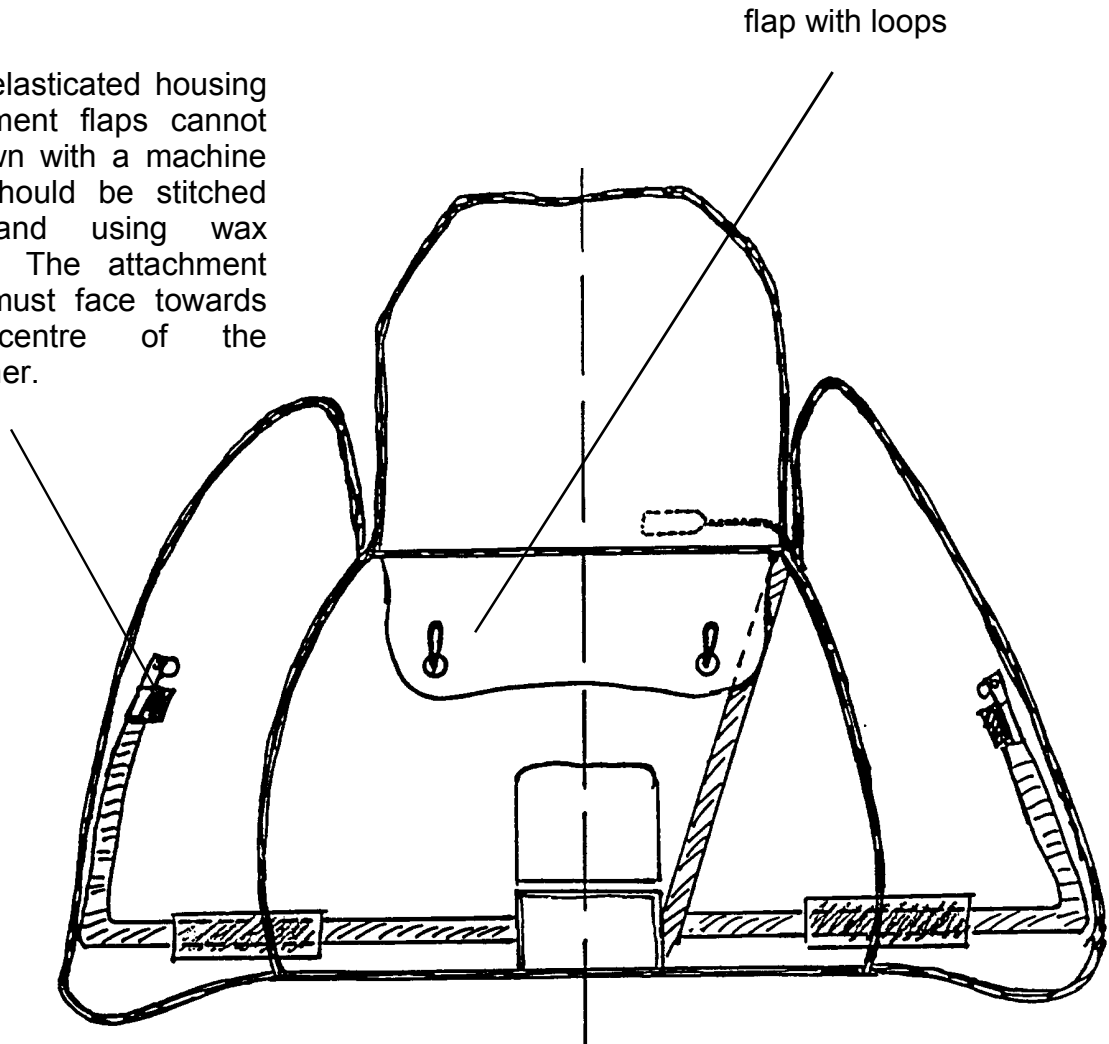

unit cable housing routed underneath the velcro strips

To enable the release unit cables to reach both flaps, the pocket for the processing unit should be mounted centrally on the bottom of the container with the spare cable pocket shortened as shown in the diagram and flush with the container's partition wall.

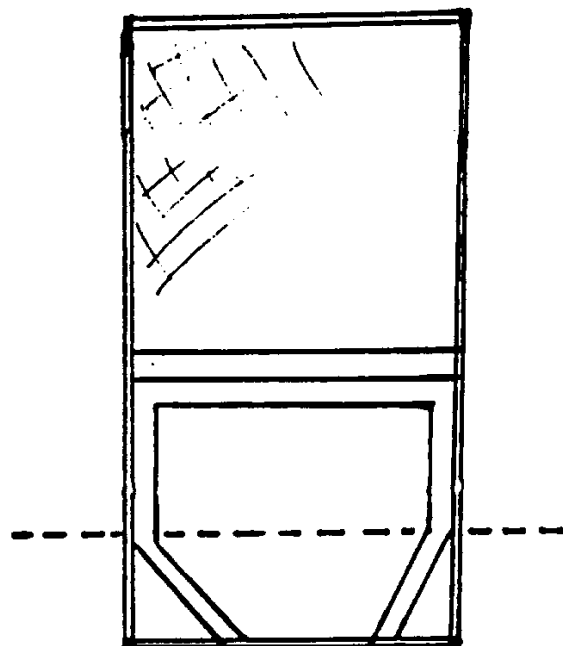

Dual Hawk Tandem (continued)

- Route the control unit cable direct to the right hand edge of the top flap.
- Route the release unit cable housings on the bottom of the container close to the partition wall. The correct routing for the cable housings is underneath the velcro patches on the side flaps. It is therefore necessary to remove the velcro patches and reaffix them on top of the housing. The cable housing should be sewn in position in addition to the use of its self adhesive backing.

Dual Hawk Tandem (continued)

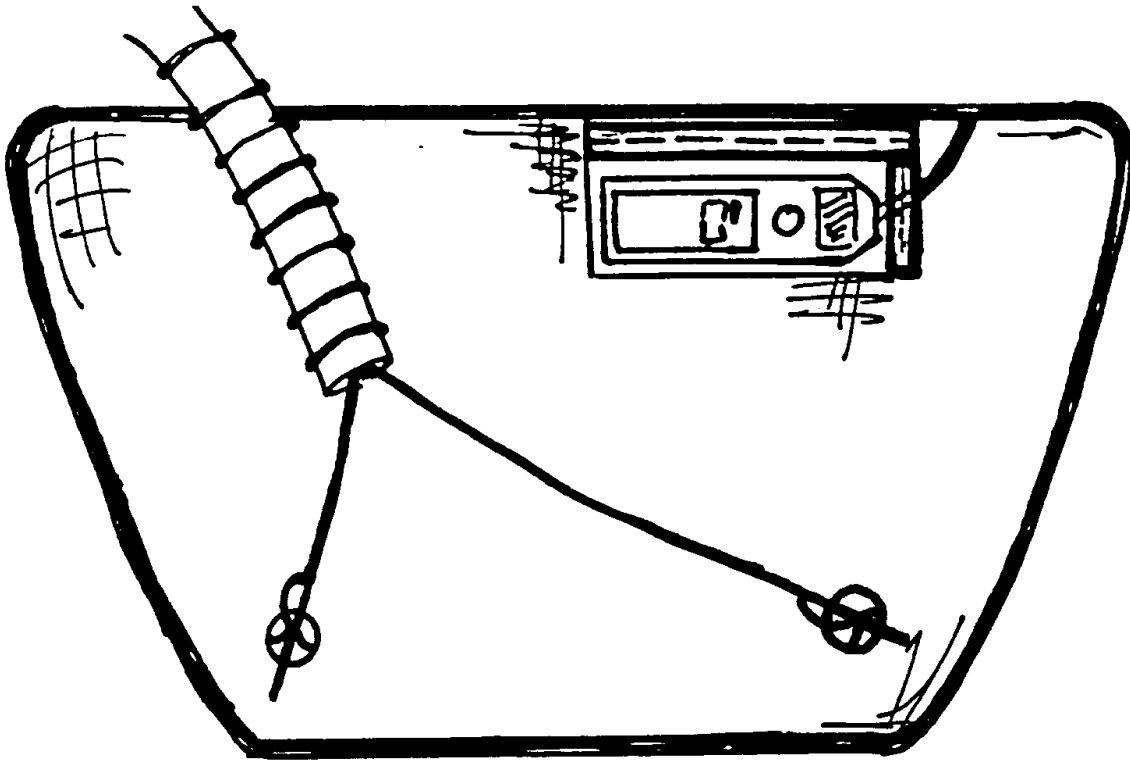

Attach the control unit horizontally on the upper right corner of the cover flap using the nylon fixing ties or the transparent pocket.

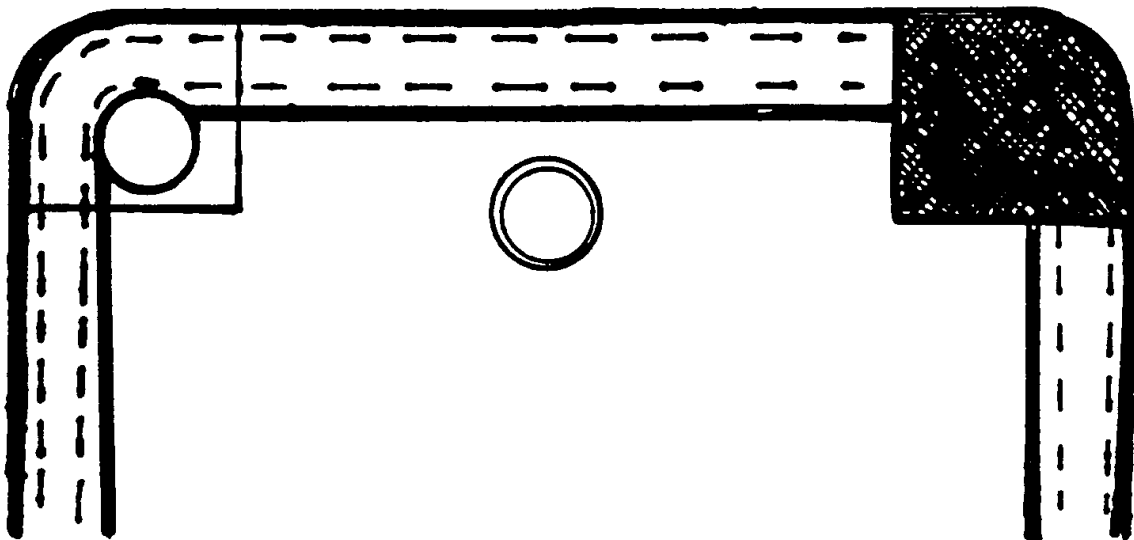

To secure the loops in the grommets we recommend the use of elastic retaining patches. Alternatively, the Cypres loop support discs can be sewn directly to the flap.

Vector Tandem

Tandem Vector I: see Vector I

Tandem Vector II: see Vector II

Galaxy Tandem

see Vector I

LOR II: see page 56

Zerox

see Vector I, not Vector II

Swift II

- Position processing unit so that the spare cable pocket is to the right.
- Control unit and control unit cable like Swift I.
- Route the **first** release element cable through the cable channel of the control unit to the **upper grommet in the pack tray**.
- Align this release unit (EOS) so that it lies parallel to the short axis of the container like in the Tear Drop., ensuring that the loop hole is in line with the right hand inner edge of the grommet.
- Route the **second** release element cable like in the Vector II on the **bottom flap** (flap # 1).
- Align this release unit (EOS) so that it lies parallel to the short axis of the container like in the Vector II.

Eclipse

- The processing unit is located in the middle of the partition wall so that the spare cable pocket is to the right.
- Control unit is located in an elastic pouch in the collar area of the rig. The control unit is visible from the back of the rig. This installation can be done by the rig manufacturer only. Rigs with factory set-up will have the control unit located at this point.

On CYPRES retro-fits the control unit has to be installed on flap 6 next to the reserve ripcord housing either in the clear plastic pocket or with the ties. See Vector I for further information.

- The cable housing for the control unit can be glued to the bottom of the container or alternatively, the cable can be routed through the double fabric layer of the bottom of the container, in which case a small 1/2" passage hole must be cut with a hot knife. See also Vector I. If you use the cable housing we recommend to secure the channel with wax thread at the bottom and the top.
- The release unit should be mounted on the inner surface of bottom flap 2. Please refer to Vector II section for details of attaching the release unit.
- **IMPORTANT:** CYPRES can only be installed, when an original Eclipse reserve pilot chute (part number E1000-2) is used.

Vector III

- Every Vector III should already be equipped with a factory Cypres set-up by Relative Workshop.
- In case you find a rig without the set-up, please contact the rig manufacturer.
- **IMPORTANT:** Cypres can only be installed, when an original Vector II reserve pilot chute is used.

Dolphin

- Every Dolphin should already be equipped with a factory Cypres set-up by Altico.
- In case you find a rig without the set-up, please contact the rig manufacturer.
- **IMPORTANT:** Cypres can only be installed, when **an original Dolphin free bag** is used.

Prestige

- Position the processing unit so that the spare cable pocket is to the right.
- Route the control unit cable housing through the double skin of the container, it must run vertically through the pack tray. Secure the cable with a couple of loose tacks which will prevent sideways movement whilst allowing the cable to flex. There is no need to make a hole for the cable at the top of the container. It passes easily between the two nylon layers at the top of the pack tray.
- Fix the control unit inside the collar area above the reserve container horizontally using the transparent pocket. The control unit must not be allowed to come into contact with the reserve ripcord housing. Note during packing: When the top flaps are folded completely open (to insert the freebag, etc.) make sure that the reserve housing does not smash or damage the display of the control unit.
- The release unit housing is attached to the right hand flap in the form of a "T" (see drawing).

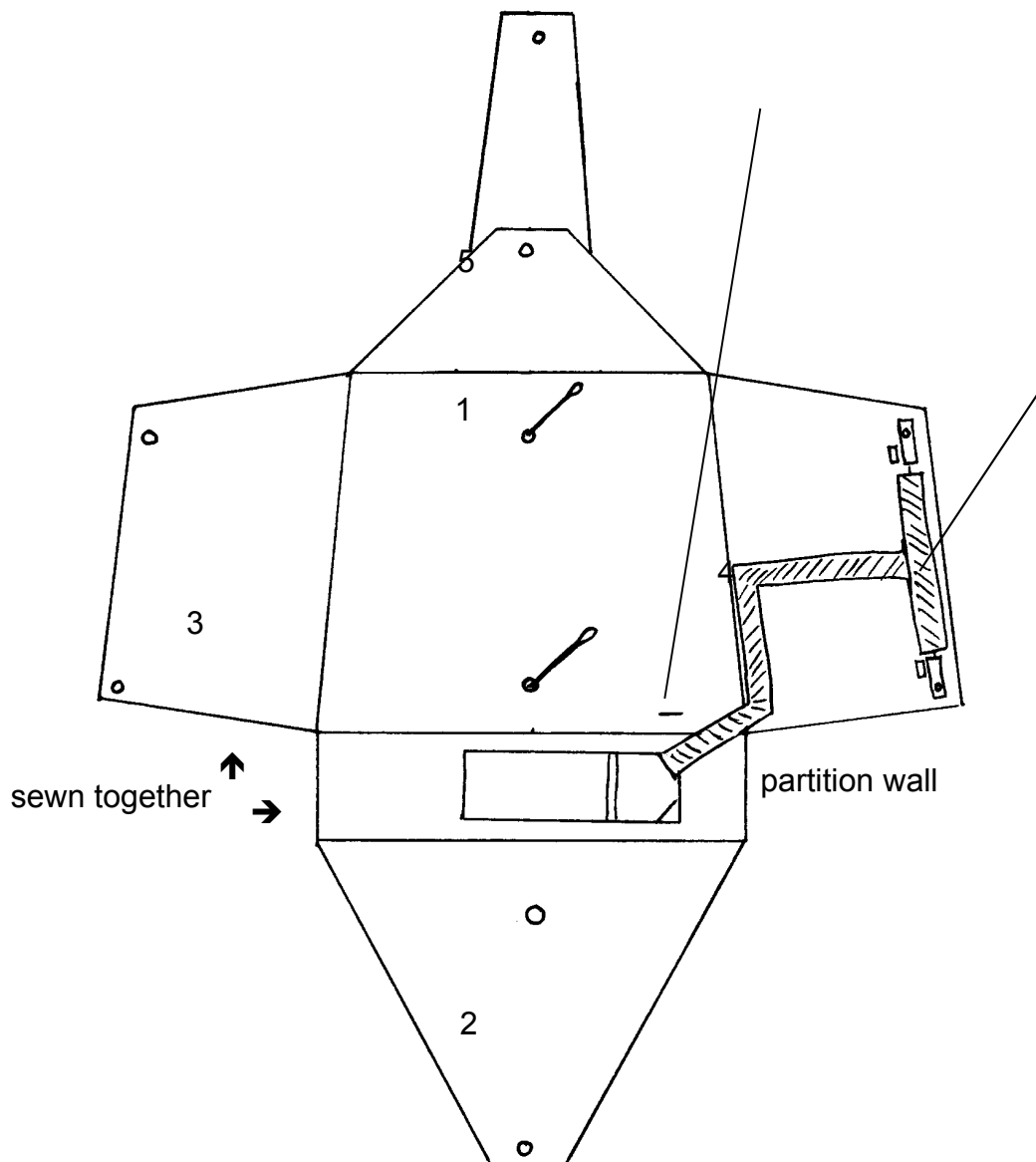

Sidewinder

- Same as Vector I, **not Vector II**.
- The Sidewinder has got 5 reserve flaps (not 6 like the Vector I). The first side flap above the pilot chute is flap 2. The cutter has to be installed on this flap.
- **Important:** Leave adequate cable slack on the control unit cable at top of rig, so it can't be stressed during packing.

Orion

same as Vector I, **except**:

- The order of flaps 3 and 4 can be reversed compared with the order normally used by most manufacturers. In this case the cutter has to be mounted on flap #4 (the right flap), and this flap has to be closed before the left one. The closing sequence is then 1 - 2 - 4 - 3 - 5 - 6. It is useful to change the numbers on the side flaps, this will help other riggers/reservepackers to close the container in the correct closing sequence.
How ever the side flaps are numbered, the release element has to be mounted on the right reserve flap which then closes before the left one.

cut for control unit cable channel

cable channel

Should you wish to install Cypres in a rig for which no instructions are contained in this manual, we will be happy to offer assistance and advice. Please provide as much of the following information as you can:

1. Name of system
2. Manufacturer
3. Year of manufacture
4. Reserve canopy

Reserve container

If it is a system with internally mounted reserve pilot chute:

5. How many ripcord pins are used to keep the reserve container closed?
6. How many flaps are underneath the pilot chute?
7. How many flaps cover the pilot chute?

If it is a two-pin reserve container:

8. What is the distance between grommets on the bottom of the container (centre of hole to centre of hole)?

Reserve canopy

If it is a round reserve:

9. Is a diaper used?
10. Is it a short diaper?
11. Is it a long diaper?

If it is a square reserve:

12. Is the free bag used the original one belonging to the container?

If it is a one-pin free bag:

13. Is it a "molar" type single grommet freebag as in the Javelin?

If it is a two-pin free bag:

14. What is the distance between the two grommets (centre of hole to centre of hole)?

Airtec GmbH

Mittelstrasse 69

33181 Bad Wünnenberg - Germany

Tel: +49 2953 98990

Fax: +49 2953 1293